

***DT SWISS***

***FORKS***

**F 232 ONE**

SERVICE CENTER MANUAL

V2021.10

<b>1. USER INFORMATION .....</b>	<b>3</b>
1.1 GENERAL.....	3
1.2 GENERAL MAINTENANCE INFORMATION .....	4
1.3 WARRANTY.....	4
<b>2. OVERVIEW .....</b>	<b>5</b>
2.1 FORK OVERVIEW .....	5
2.2 SERVICE KITS .....	6
2.3 TOOLS .....	9
<b>3. SAFETY .....</b>	<b>10</b>
<b>4. SERVICE INFORMATION .....</b>	<b>11</b>
4.1 GENERAL.....	11
4.2 SERVICE INTERVALS.....	11
4.3 SERVICE WORKS .....	11
<b>5. DISASSEMBLING .....</b>	<b>12</b>
5.1 RELEASING THE AIR.....	13
5.2 DISASSEMBLING THE CONTROL ELEMENTS.....	14
5.3 DISASSEMBLING THE LOWER UNIT .....	17
5.4 DISASSEMBLING THE DAMPING UNIT.....	19
5.5 DISASSEMBLING THE SPRING UNIT.....	22
5.6 DISASSEMBLING THE VOLUME REDUCTION SPACER.....	23
<b>6. SERVICING.....</b>	<b>24</b>
6.1 CHANGING THE WIPER SEALS .....	24
6.2 CHANGING THE O-RINGS OF THE DAMPING UNIT .....	26
6.3 CHANGING THE O-RINGS OF THE SPRING UNIT .....	29
<b>7. ASSEMBLING.....</b>	<b>31</b>
7.1 ASSEMBLING THE DAMPING UNIT .....	33
7.2 GREASING THE STANCHION TUBE.....	36
7.3 SETTING THE VOLUME REDUCTION SPACER.....	37
7.4 ASSEMBLING THE SPRING UNIT.....	39
7.5 ASSEMBLING THE AIR CHAMBER CAP.....	40
7.6 ASSEMBLING THE LOWER UNIT.....	40
7.7 ASSEMBLING THE CONTROL ELEMENTS.....	42

# 1. USER INFORMATION

## 1.1 GENERAL

### VALIDITY

This manual describes the component specified on the front page and the footer. It is valid for the construction level of the component on the 01.11.21.

Deviations are possible and all items are subject to technical changes.

### SAFETY

The safety instructions are classified as follows:



#### **DANGER**

... indicates a hazard with a high level of risk which, if not avoided, will result in death or serious injury.



#### **WARNING**

... indicates a hazard with a medium level of risk which, if not avoided, may result in minor or moderate injury.



#### **NOTE**

... indicates a potentially hazardous situation that may result in damage to property.

### TARGET GROUP

This manual is only intended for DT Swiss service centers.

The works described in this manual may only be done by skilled professionals trained by DT Swiss.

### LAYOUT

The cover page and the footing provide information about the type of product and manual as well as the version of the manual.

The backside provides a list of the DT Swiss service centers. A list of all DT Swiss service centers can be found at [www.dtswiss.com](http://www.dtswiss.com).

This manual is intended for being printed as an A5 booklet. Only print this manual if electronic usage is not possible.

## **DT SWISS MANUAL CONCEPT**

The DT Swiss user and service information is split into the following types of manuals:

- **User Manual**  
Information for the end user on how to install and use the component.
- **Technical Manual**  
Detailed information for the end user and the dealer on how to maintain the component, spare parts and technical data.
- **Service Sheets**  
Small service tasks to solve current issues.
- **Service Center Manual**  
Detailed information strictly for DT Swiss service centers and suspension service points.

## **1.2 GENERAL MAINTENANCE INFORMATION**

Moving parts, threads, O-rings and sealings must be greased before assembling.

### **CLEANING**

For an optimal result of the maintenance works, every component that will be disassembled must be cleaned. Only use cleaners which do not damage the components. Especially the cleaning of O-rings and sealings requires mild cleaners. Always consider the instructions of the respective cleaner.

DT Swiss recommends the following cleaners:

- Motorex Rex
- Motorex Swissclean
- Motorex OPAL 2400, OPAL 3000, OPAL 5000

Use soap water or similar mild cleaners for external cleaning.

### **TOOLS**

To ensure a damage-free mounting and dismounting of the components, only use the tools which are mentioned in this manual. The tools must be in good order and condition.

If components are damaged by the usage of differing tools, the user is liable.

DT Swiss special tools are precision tools. Damage-free mounting and dismounting of the components can only be ensured if the tools are working properly and if the conditions of the tools are perfect.

Always keep the tools in their original packaging or adequate devices to save them from damages.

### **ENVIRONMENTAL PROTECTION**

Whenever possible, waste has to be avoided. Waste, especially carbon, lubricants, cleaners and any other fluids must be disposed in an environmentally compatible manner.

Only print this manual if electronic usage is not possible.

### **DISCLAIMER**

The operations described in this manual should only be performed by experts. The user is liable for any damage or consequential damage caused by wrong maintained or wrong installed components. If you have doubts, please contact your allocated DT Swiss pro level service center.

## **1.3 WARRANTY**

Warranty conditions can be found at [www.dtswiss.com](http://www.dtswiss.com).

## 2. OVERVIEW

### 2.1 FORK OVERVIEW

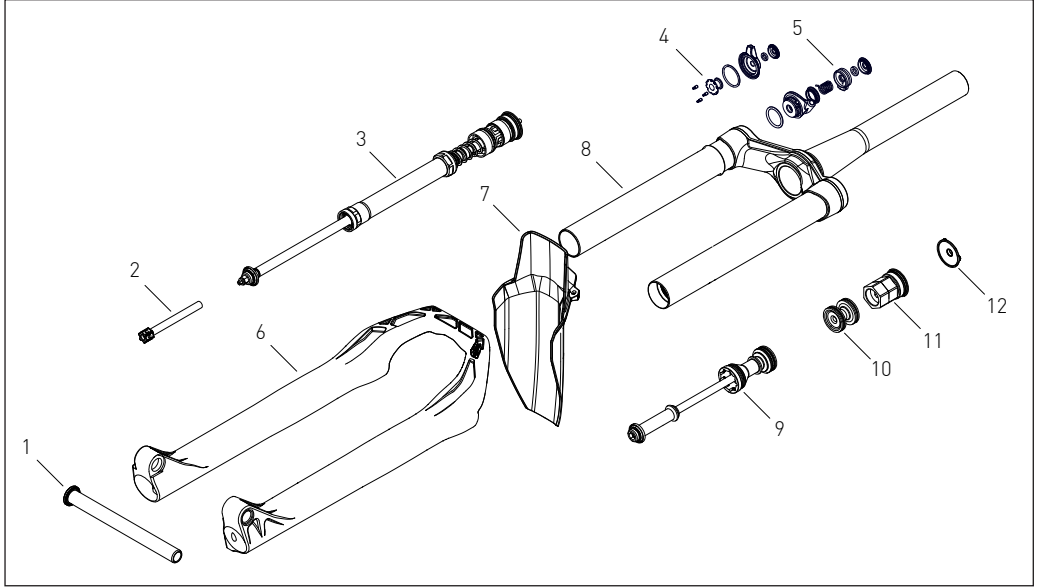

Pos	Description	Pos	Description
1	RWS axle	7	fender
2	rebound adjuster	8	upper unit
3	damping unit	9	spring unit
4	manual control elements	10	volume reduction spacer
5	remote control elements	11	air chamber cap with volume spacers
6	lower unit	12	valve cap

## 2.2 SERVICE KITS

### SEAL KIT DAMPING UNIT

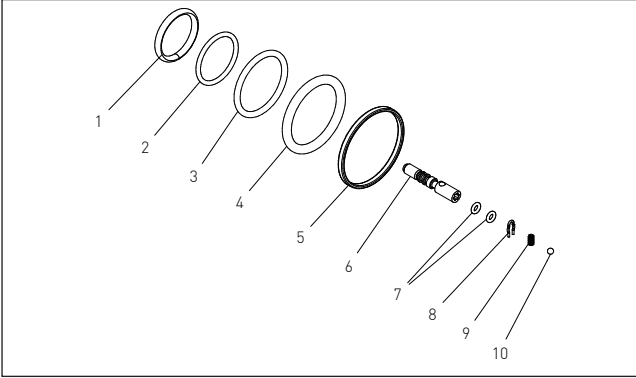

Art.No. FWKXXXXXXXXX28871S

- 1 O-ring  $\varnothing 15 \times 2$  mm
- 2 O-ring  $\varnothing 16 \times 1.5$  mm
- 3 O-ring  $\varnothing 20 \times 2$  mm
- 4 O-ring  $\varnothing 22 \times 3$  mm
- 5 O-ring  $\varnothing 26 \times 1.5$  mm
- 6 compression pin
- 7 2x O-ring  $\varnothing 2 \times 1$  mm (already mounted on the compression pin)
- 8 clip
- 9 spring
- 10 ball  $\varnothing 2$  mm

### SEAL KIT SPRING UNIT

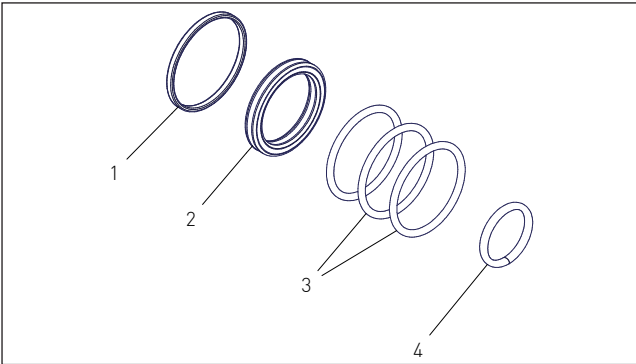

Art.No. FWKXXXXXXXXX28872S

- 1 O-ring  $\varnothing 26 \times 1.5$  mm
- 2 quadring
- 3 3x O-ring  $\varnothing 24 \times 2$  mm
- 4 O-ring  $\varnothing 15 \times 2$  mm

### WIPER SEAL KIT $\varnothing 32$

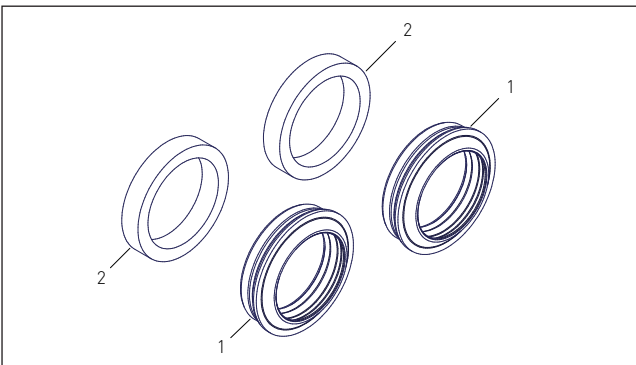

Art.No. FWKXXXXXXXXX46388S

- 1 2x wiper seal  $\varnothing 32$
- 2 2x foam ring

## WIPER SEAL KIT

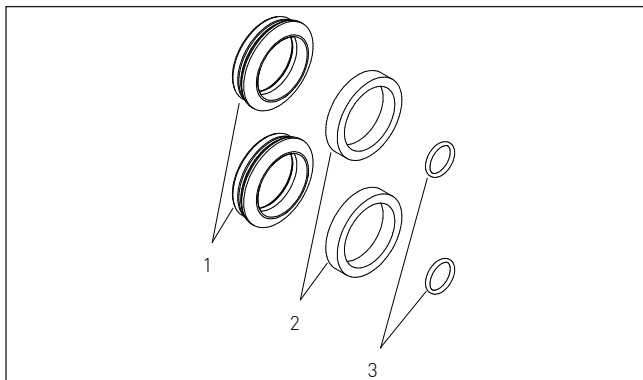

Art.No. FWKXXXXXXXXX31066S

- 1 2x wiper seal  $\varnothing 32$
- 2 2x foam ring
- 3 2x O-ring  $\varnothing 15 \times 2$  mm

## CLIPS KIT ICP

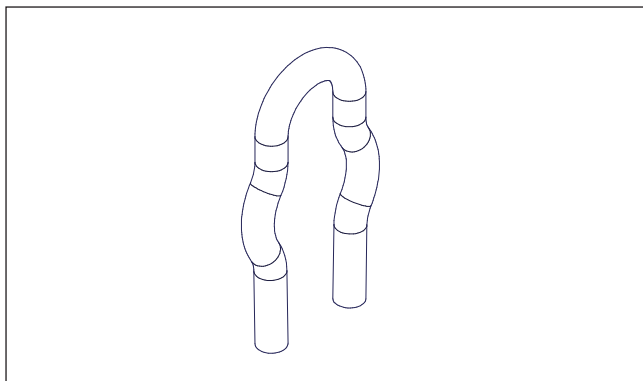

Art.No. FWKXXXXXXXXX20370S

20x clip

## SPRING AND BALL KIT

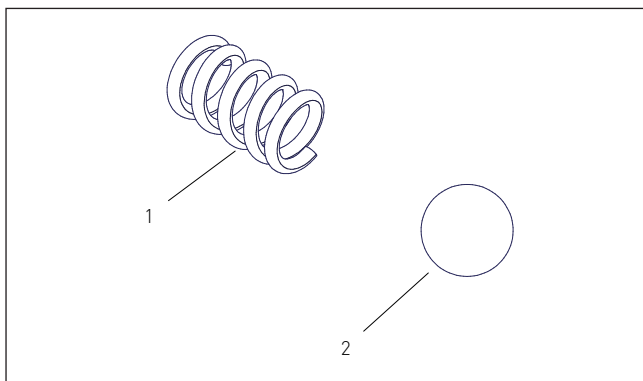

Art.No. FWKXXXXXXXXX20416S

- 1 20x spring
- 2 20x ball

## DUST SEAL KIT REMOTE ICP

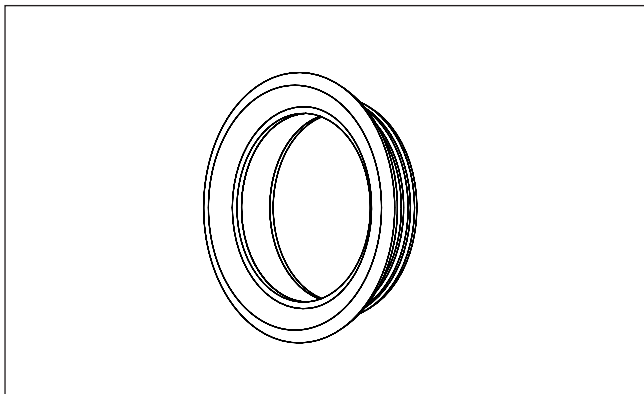

Art.No. FWKXXXXXXXXX21572S

5x dust seal

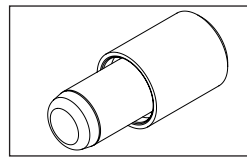
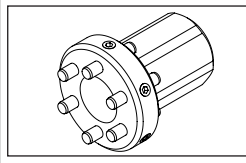
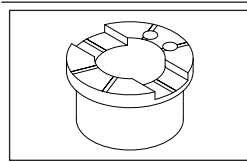
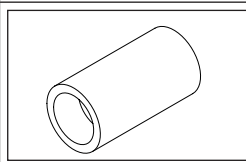
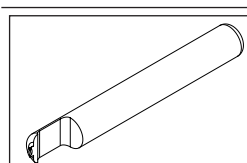
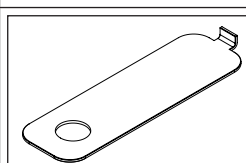
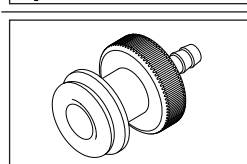
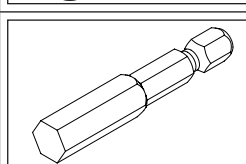
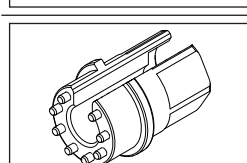
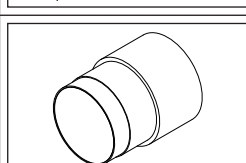
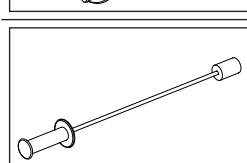
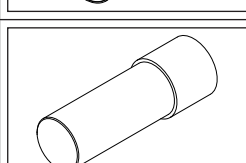
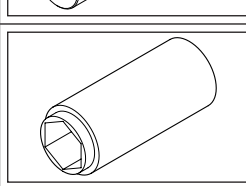

## 2.3 TOOLS

Art.No. / Description		Art.No. / Description	
	FWTXXXXXXXXX013089S presstool wiper seal Ø32		FXTXXXXXXX011744S damping unit mounting tool
	FXTXXXXXXX10028553S assembly tool clip		FXTXXXXXXX018400S ball & spring mounting tool
	FXTXXXXXXX10018855S clip assembly tool		FXTXXXXXXX018412S clip extraction tool
	FWTXXXXXXX12840S bleeding tool		FXTXXXXXXX018482S reworked hex bit 8 mm
	FWTXXXXXXX10024414S spring unit mounting tool		FXTXXXXXXX10028188S volume reduction spacer mounting tool
	FWTXXXXXXX018638S stanchion grease tool		FXTXXXXXXX10028191S volume reduction spacer positioning tool
			FXTXXXXXXX018645S reworked hex socket 8 mm

### 3. SAFETY



#### **DANGER**

##### **DANGER TO LIFE DUE TO WRONG MAINTENANCE!**

Incorrect maintenance or assembly can lead to unpredictable errors!

- Maintenance and assembly must only be done by a skilled professional.
- In case of any doubt, contact a DT Swiss service center.



#### **DANGER**

##### **RISK OF INJURY DUE TO HIGH AIR PRESSURE!**

Air with high pressure can escape suddenly while dismantling the fork!

- Always release the air before starting any works.



#### **DANGER**

##### **RISK OF INJURY FROM PRESSURIZED COMPONENTS!**

If the spring unit or the air chamber cap is removed without first releasing the air, the spring unit or the air chamber cap is ejected from the stanchion after loosening the screw connection.

- Release the air completely before unscrewing the spring unit or the air chamber cap.
- While deflating the air, move the fork several times through the travel and deflate the air again. (see „5.1 Releasing the air“ on page 13).
- Components that may be under pressure must never point towards the face or body during disassembly.

## 4. SERVICE INFORMATION

### 4.1 GENERAL

Before starting the fork service, you should check all functions of the fork. In the case of a specific error, specific measures must be taken.

### 4.2 SERVICE INTERVALS

If service intervals are not respected, any warranty claims can be denied.

Action	Interval
Full service A full service must be executed by a DT Swiss service center.	annually or after 200 operating hours*
Small service A small service can be executed by a DT Swiss service center, a skilled dealer or user.	50 operating hours*

\* If the bike is used in extreme conditions, the components must be serviced sooner.

### 4.3 SERVICE WORKS

Action	Small Service	Full Service	Link
Disassembling the control elements		X	chap. 5.2 on page 14
Disassembling the lower unit	X	X	chap. 5.3 on page 17
Disassembling the damping unit		X	chap. 5.4 on page 19
Disassembling the spring unit		X	chap. 5.5 on page 22
Changing the wiper seals	X	X	chap. 6.1 on page 24
Changing the O-rings of the damping unit		X	chap. 6.2 on page 26
Changing the O-rings of the spring unit		X	chap. 6.3 on page 29
Assembling the damping unit		X	chap. 7.1 on page 33
Assembling the spring unit		X	chap. 7.4 on page 39
Assembling the lower unit	X	X	chap. 7.6 on page 40
Assembling the control elements		X	chap. 7.7 on page 42

## 5. DISASSEMBLING

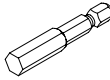
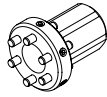
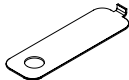
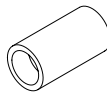
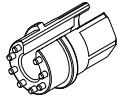
Preparatory Steps	Link	
Clean the fork	„CLEANING“ on page 4	
Required Tools and Material	Quantity	Article number
reworked 8 mm hex nut		1 FXTXXXXXXXXX018645S
special 8 mm internal hex bit		1 FXTXXXXXXXXX018482S
mounting tool for damping unit		1 FXTXXX0XXX011744S
clip extraction tool		1 FXTXXXXXXXXX018412S
tool for ball and spring		1 FXTXXXXXXXXX018400S
spring unit mounting tool		1 FWTXXXXXX10024414S

## 5.1 RELEASING THE AIR

1. Unscrew the valve cap.

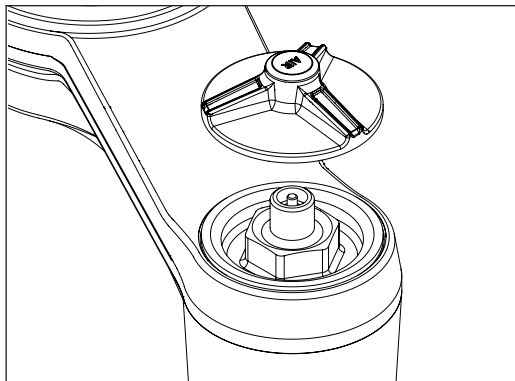

2. Release the air SLOWLY by pressing the valve insert.
3. With the valve insert pressed, slowly compress the fork twice by about 10 mm and then decompress fully.  
→ This equalises the positive and negative air chambers.

## 5.2 DISASSEMBLING THE CONTROL ELEMENTS

### 5.2.1 REMOVING THE REMOTE CONTROL ELEMENTS

1. Pull off the compression cover.

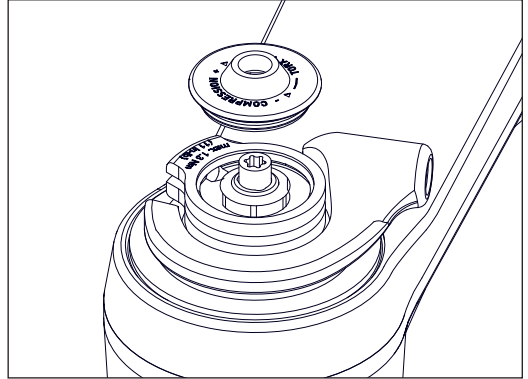

2. Unscrew the nut of the remote wheel using the tool FXTXXXXXXXXX018645S.

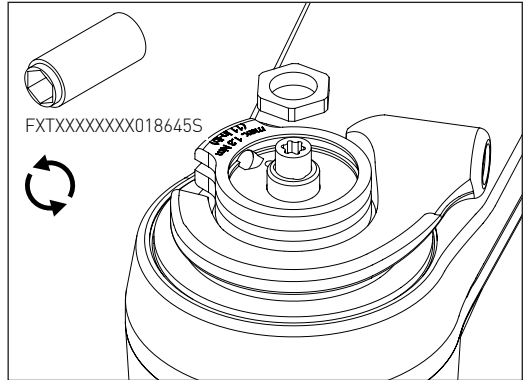

3. Pull off the remote wheel.

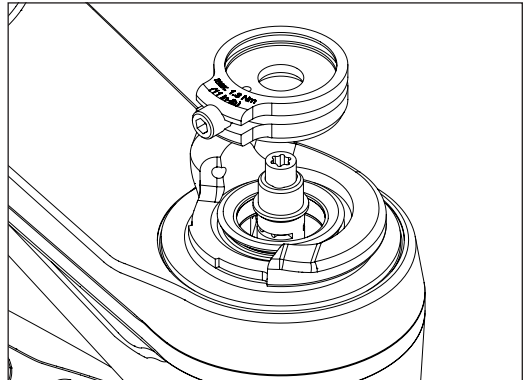

4. Remove the cable guide with dust seal and spring.
5. Remove the O-ring.

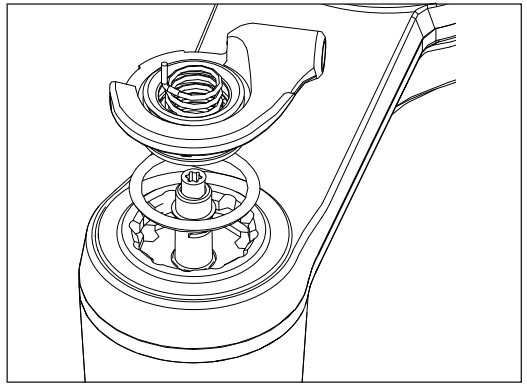

### 5.2.2 REMOVING THE MANUAL CONTROL ELEMENTS

1. Pull off the compression cover.

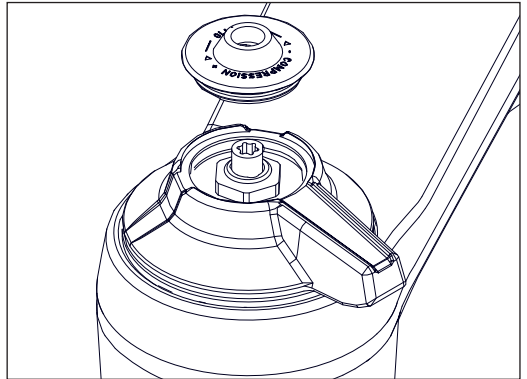

2. Hold the lever with one hand.  
→ The lever must not turn while unscrewing the nut!
3. Unscrew the nut of the remote wheel using the tool FXTXXXXXXXXX018645S.

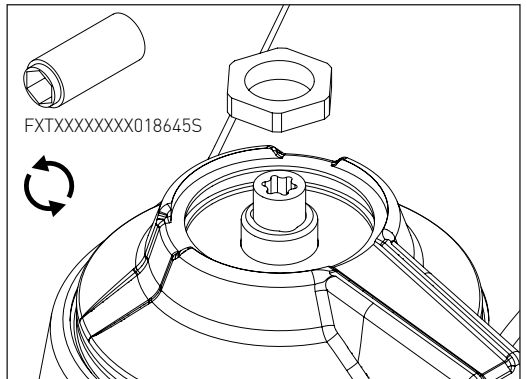

4. Remove the lever and the O-ring underneath.

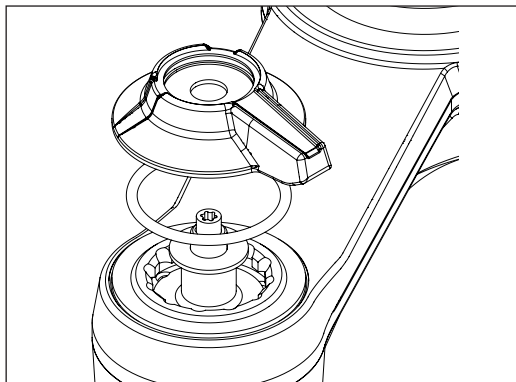

5. Remove the raster wheel, the raster caps and the springs.

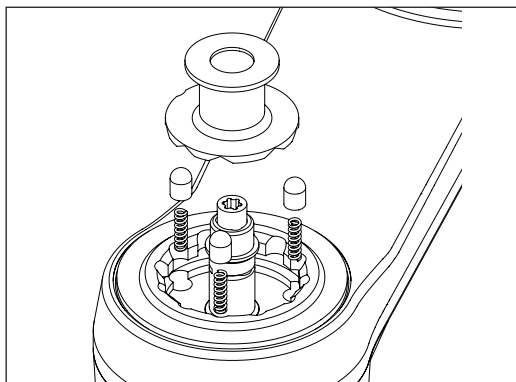



### 5.3 DISASSEMBLING THE LOWER UNIT

1. Hold the rebound adjuster using a 12 mm wrench and unscrew the fixing screw of the rebound adjuster using a long 2.5 mm hex key.

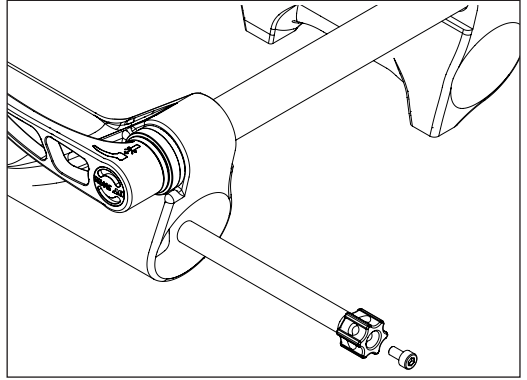

2. Ensure that the air has been released completely (see „5.1 Releasing the air“ on page 13).

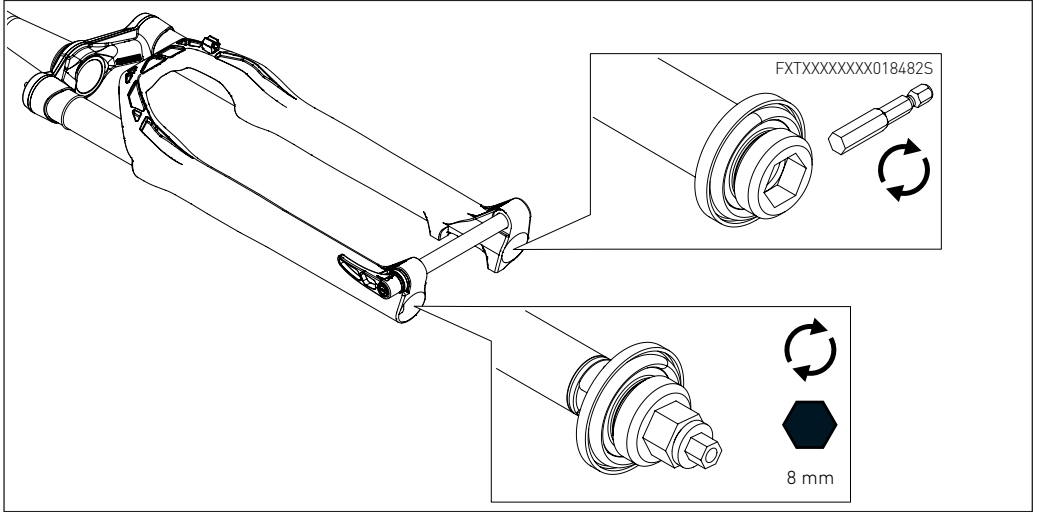

3. Screw the screw on the spring side into the dropout clockwise using the tool FTXXXXXXXXX0184825.
4. Screw the screw on the damping side into the dropout clockwise using an 8 mm hex nut.  
→ After the screws are screwed in, about 14 ml oil will leak out of each dropout. Collect the leaking oil using a suitable container.

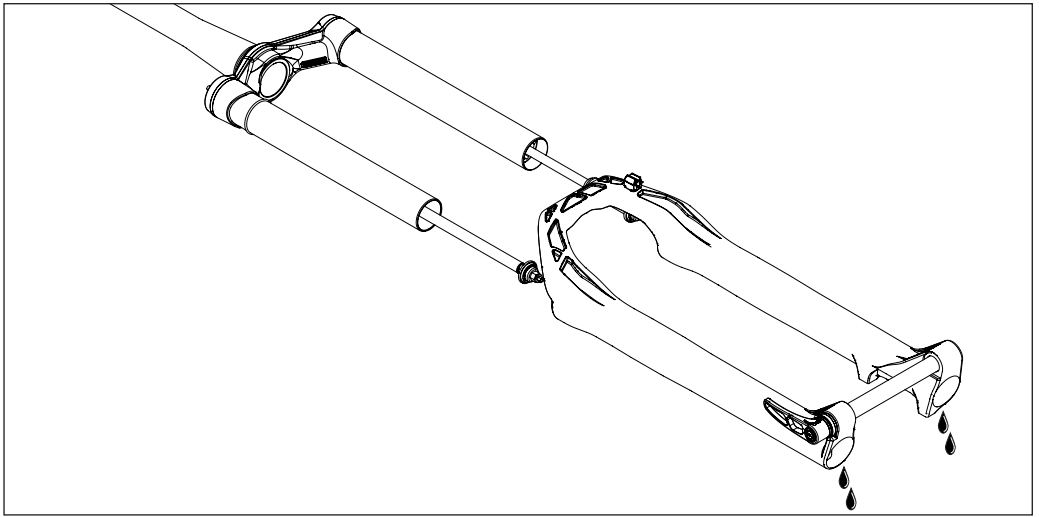

5. Remove the lower unit carefully.  
→ The O-rings on the connectors may fall off after removing the lower unit. Ensure that the O-rings do not stay inside the lower unit.
6. Collect the leaking oil using a suitable container.

## 5.4 DISASSEMBLING THE DAMPING UNIT

1. Unscrew the damping unit using the special installation tool FXTXXX0XXXX011744S.
2. Pull out the damping unit.  
→ Collect the leaking oil using a suitable container.

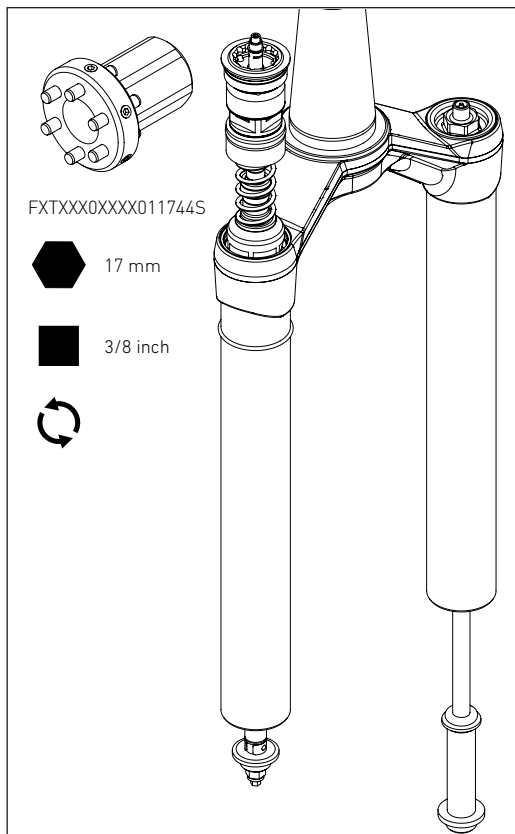

## 5.4.1 REMOVING THE COMPRESSION PIN

1. Make sure the compression pin is not screwed in or out to the maximum.
  - If the compression pin is screwed in or out to the maximum, removing it will be difficult.
2. Push the clip out of the compression pin using the tool FXTXXXXXXXXX018412S and forceps.

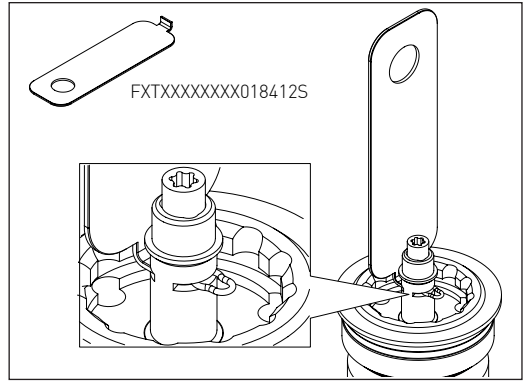

3. Put the tool FXTXXXXXXXXX018400S onto the compression pin and unscrew the compression pin using a Torx T10.
  - The tool FXTXXXXXXXXX018400S prevents the ball and the spring inside the compression pin from falling out.

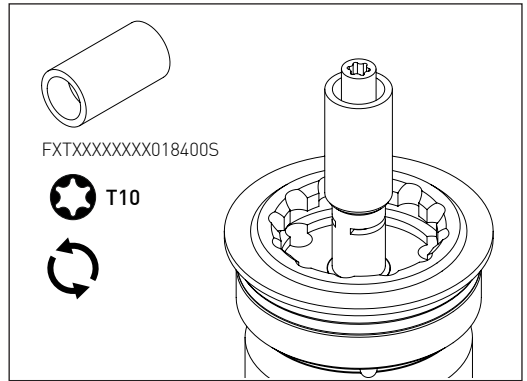

4. Remove the oil from the damping unit by pushing and pulling the damping rod.

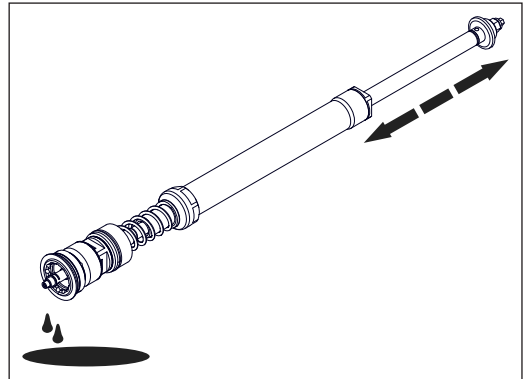

## 5.4.2 RELEASING THE OIL FROM THE DAMPING UNIT

1. Unscrew the oil chamber using a 17 mm and a 24 mm open end wrench.

OR

2. Clamp the hex of the rebound unit into a vice and unscrew the oil chamber using a 24 mm open end wrench.

→ One of both screw joints loosens.



No Loctite must get into the oil chamber of the damping unit!



The oil chamber must not be clamped!

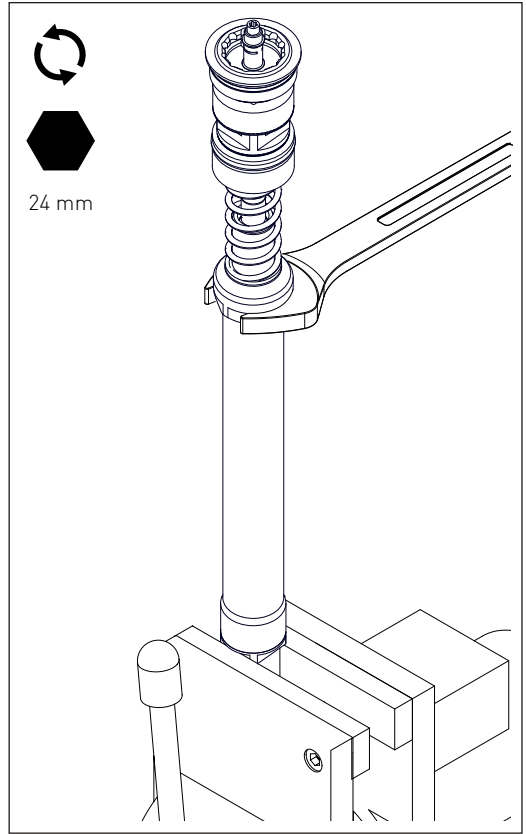

3. Release the entire oil by pushing in the damping rod.

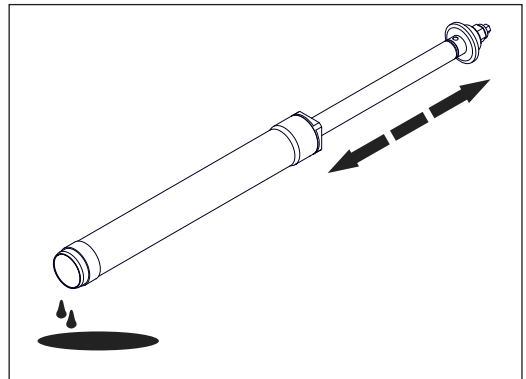

## 5.5 DISASSEMBLING THE SPRING UNIT



### DANGER

#### RISK OF INJURY FROM PRESSURIZED COMPONENTS!

If the spring unit or the air chamber cap is removed without first releasing the air, the spring unit or the air chamber cap is ejected from the stanchion after loosening the screw connection.

- Release the air completely before unscrewing the spring unit or the air chamber cap.
- While deflating the air, move the fork several times through the travel and deflate the air again. (see „5.1 Releasing the air“ on page 13).
- Components that may be under pressure must never point towards the face or body during disassembly.

1. Ensure that the air has been released (see „5.1 Releasing the air“ on page 13).
2. Unscrew the air chamber cap.

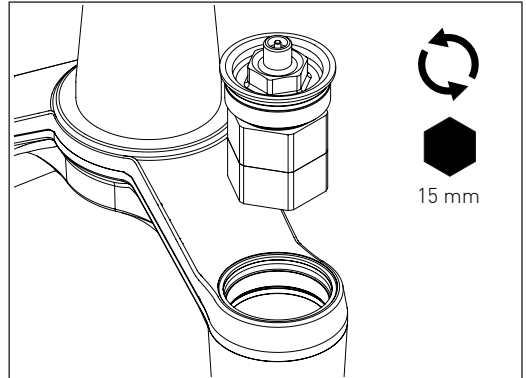

3. Unscrew the spring unit using the tool FWTXXXXX10024414S
4. Pull out the spring unit from the bottom.

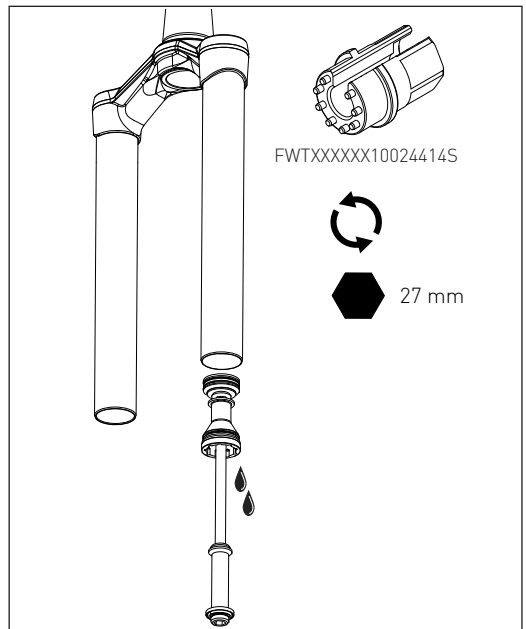

## 5.6 DISASSEMBLING THE VOLUME REDUCTION SPACER

1. Push out the volume reduction spacer from the top using a suitable plastic tool.

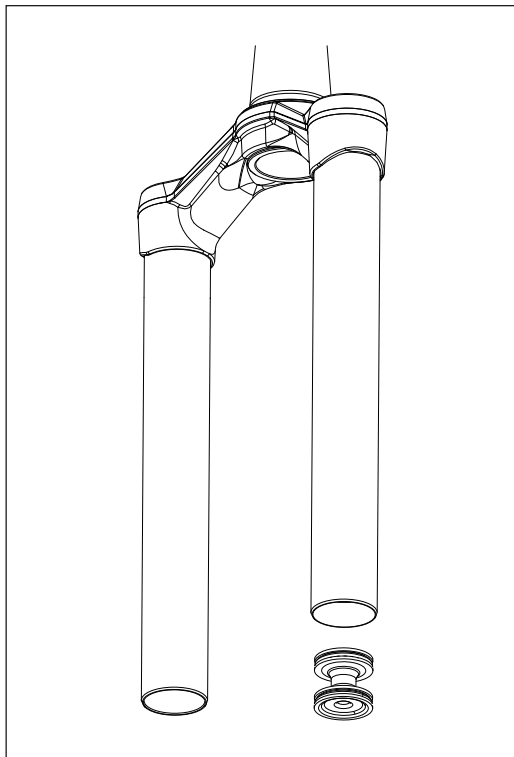

### Closing Steps

Servicing the fork

### Link

„6. Servicing“ on page 24

## 6. SERVICING

### 6.1 CHANGING THE WIPER SEALS

#### Preparatory Steps

Disassembling the lower unit

#### Link

„5.3 Disassembling the lower unit“ on page 17

#### Required Tools and Material

Wiper Seal Kit Ø32 (2x wiper seal, 2x foam ring)

OR

Wiper Seal Kit Ø32  
(2x wiper seal, 2x foam ring, 2x O-ring connector)  
(can be used if only a small service will be done)

presstool wiper seal Ø32 SKF

Solid tire lever

DT Swiss Lube Fluid

#### Quantity

1

1

1

100 ml

1000 ml

#### Article number

FWKXXXXXXXXX46388S

FWKXXXXXXXXX31066S

FWTXXXXXXXXX013089S

-

4064XXXXXXXXX000026

4064XXXXXXXXX000028

#### 6.1.1 REMOVING THE WIPER SEALS

1. Remove both foam rings below the wiper seals.

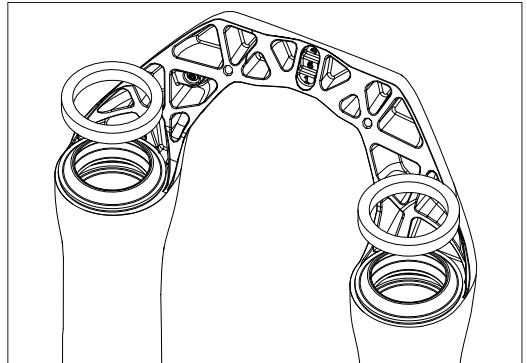

2. Remove both wiper seals using a solid tire lever.



NOTE: The lower unit must not be damaged when removing the wiper seals!

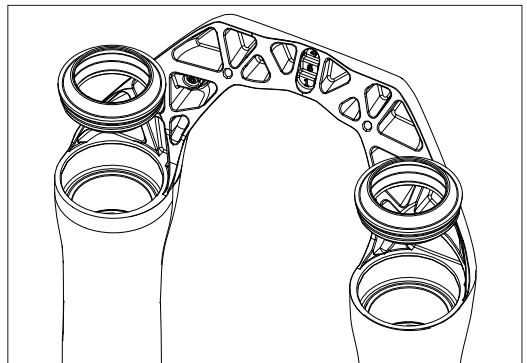



## 6.1.2 MOUNTING THE WIPER SEALS

1. Clean the lower unit with an appropriate cleaner.
  - If you are using soap water, flush the lower unit with clear water after cleaning.
  - There must be no residual moisture inside the lower unit before re-mounting.
  - Only use lint-free textile cloths.
2. Slide the tool FWTXXXXXXXXX013089S into the first wiper seal.
3. Carefully drive in the wiper seal using a hammer.
4. Remove the tool from the wiper seal.
5. Repeat steps to mount the second wiper seal.
6. If small rubber slices were cut off from the wiper seal when pressing in, remove them.

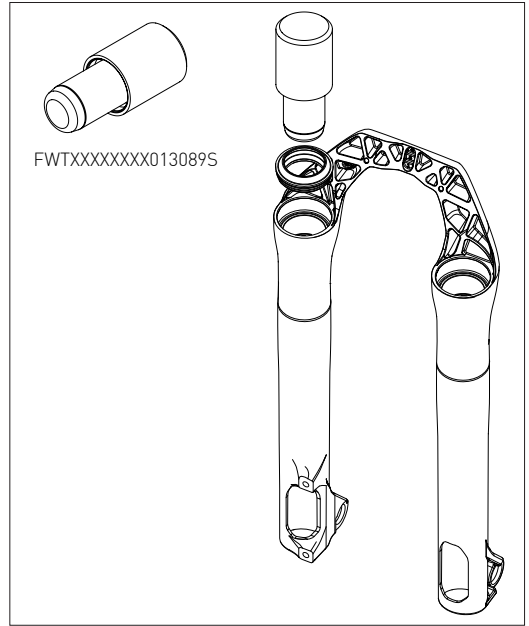

7. Put two new, in DT Swiss Lube Fluid soaked foam rings between the bushings and the wiper seals.

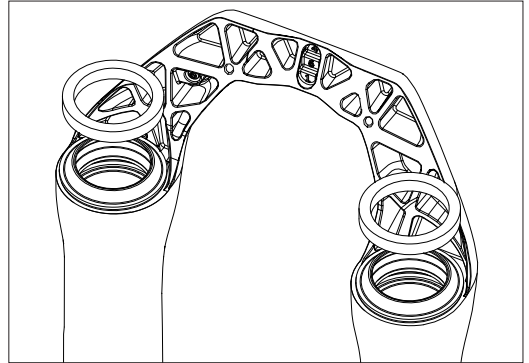

### Closing Steps

### Link

If no further service works are necessary, mount the lower unit | [„7.6 assembling the lower unit“](#) on page 40

## 6.2 CHANGING THE O-RINGS OF THE DAMPING UNIT

### Preparatory Steps

### Link

Disassembling the control elements

„5.2 Disassembling the control elements“ on page 14

Disassembling the lower unit

„5.3 Disassembling the lower unit“ on page 17

Disassembling the damping unit

„5.4 Disassembling the damping unit“ on page 19

### Required Tools and Material

### Quantity

### Article number

SEAL KIT INC

1

FWKXXXXXXXXX28871S

DT Swiss Fork Oil

100 ml

4064XXXXXXXXX000024

1000 ml

4064XXXXXXXXX000025

### 6.2.1 SEAL KIT OVERVIEW

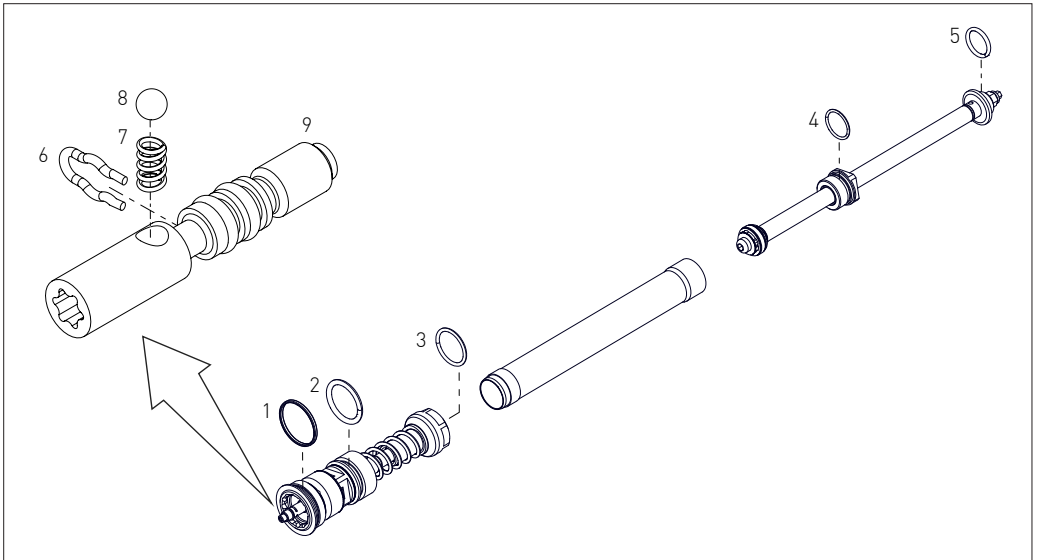

1 O-ring top unit

2 O-ring IFP tube

3 O-ring oil chamber

4 O-ring oil chamber

5 O-ring connector piece

6 clip compression pin

7 spring

8 ball



9 compression pin with O-rings

## 6.2.2 CHANGING THE O-RING OF THE OIL CHAMBER

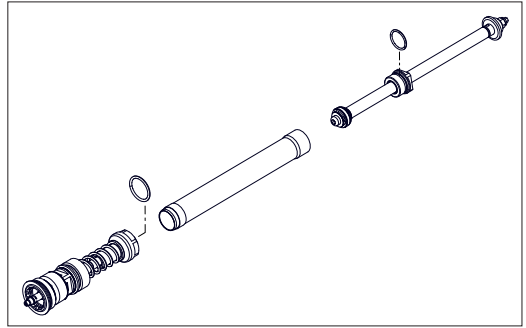
1. Remove the O-ring from the open end of the oil chamber using plastic forceps.
2. Put DT Swiss fork oil onto the new O-ring.
3. Put the O-ring onto the open end of the oil chamber.



## 6.2.3 ASSEMBLING THE OIL CHAMBER

1. Degrease and put Loctite 241 onto one of the external threads of the oil chamber.  
→ A stripe of thread lock over one third of the circumference is sufficient.  
 No Loctite must get into the oil chamber of the damping unit!
2. Clamp the hex of the rebound unit into a vice and screw on the oil chamber using the tool FXTXXX0XXX011744S.  
 The oil chamber must not be clamped!
3. Tighten the oil chamber with a torque of 10 Nm.

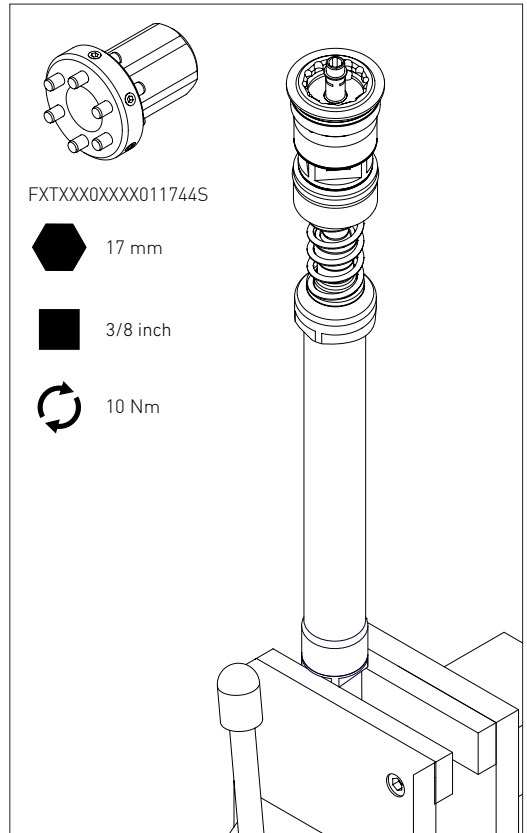

## 6.2.4 CHANGING THE OUTER O-RINGS OF THE DAMPING UNIT

1. Remove the three outer O-rings.
2. Put DT Swiss Fork Oil onto the three new O-rings.
3. Put one new O-ring onto the top unit.
4. Put one new O-ring onto the IFP tube.
5. Put one new O-ring onto the connector.

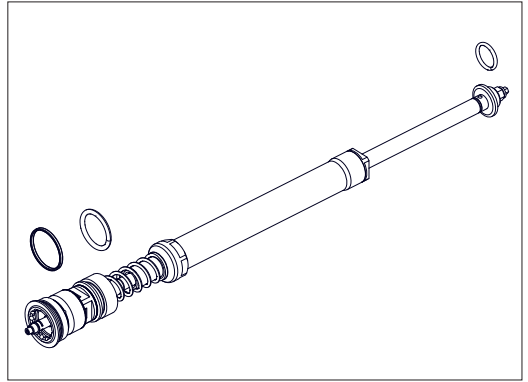

### Closing Steps

If no further service works are necessary, mount the damping unit

### Link

„7.1 Assembling the damping unit“ on page 33

## 6.3 CHANGING THE O-RINGS OF THE SPRING UNIT

### Preparatory Steps

- Disassembling the lower unit
- Disassembling the spring unit

### Link

- „5.3 Disassembling the lower unit“ on page 17
- „5.5 Disassembling the spring unit“ on page 22

### Required Tools and Material

Seal Kit Spring LNR APT

DT Swiss Fork Oil

Buzzy`s Slick Honey

### Quantity

1

100 ml

1 l

5 l

4.7 dl

20 ml

### Article number

FWKXXXXXXXXX28872S

4064XXXXXXXX000024

4064XXXXXXXX000025

4064XXXXXXXX000027

40341000AD02000001

TZXXXXXNSLICKS

### 6.3.1 SEAL KIT OVERVIEW

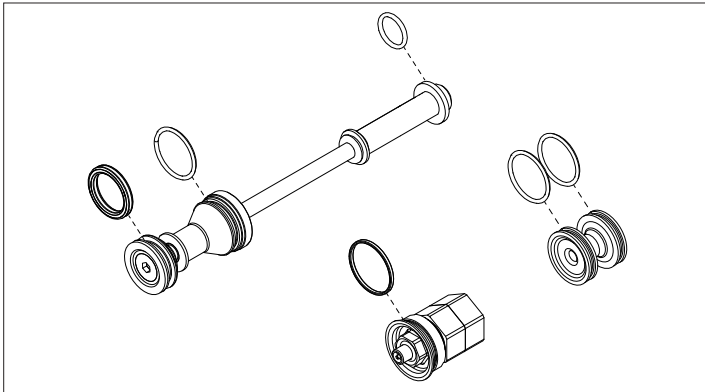

- 1 quadring
- 2 O-ring seal head
- 3 O-ring connector piece
- 4 2x O-ring volume reduction spacer
- 5 O-ring air chamber cap

### 6.3.2 CHANGING THE O-RINGS OF THE SPRING UNIT

1. Remove the quadring from the air piston.
2. Check the seat of the quadring for damages.
3. Slightly grease the new quadring with Slick Honey and put it onto the air piston.
4. Check, if the quadring is not twisted.

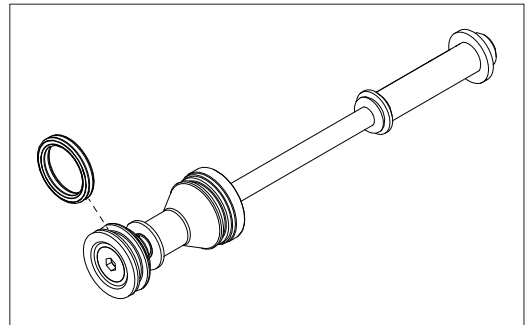

5. Remove the O-ring from the connector.
6. Slightly grease the new O-ring with Slick Honey and put it onto the connector.
7. Remove the O-ring from the lower air chamber cap.
8. Slightly lubricate the new O-ring with DT Swiss Fork Oil and put it onto the seal head.

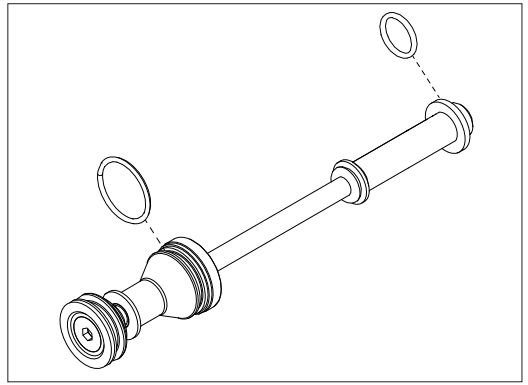

### 6.3.3 CHANGING THE O-RINGS OF THE VOLUME REDUCTION SPACER

1. Remove both O-rings from the volume reduction spacer.
2. Slightly grease the new O-rings with Slick Honey and put it onto the volume reduction spacer.

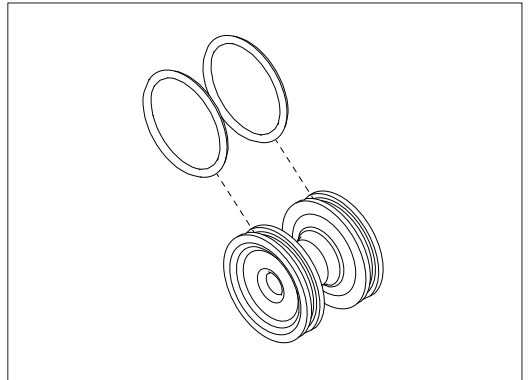

#### Closing Steps



If no further service works are necessary, mount the volume reduction spacer and the spring unit

#### Link

„7.3 Setting the Volume Reduction Spacer“ on page 37  
 „7.4 Assembling the Spring Unit“ on page 39

## 7. ASSEMBLING

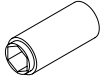
Preparatory Steps	Link	
All necessary service works are completed	„6. Servicing“ on page 24	
Required Tools and Material	Quantity	Article number
mounting tool for damping unit	1	FXTXXX0XXXX011744S
bleeding tool	1	FWTXXXXXXXX12840S
tool for ball and spring	1	FXTXXXXXXXX018400S
assembly tool clip	1	FXTXXXXXX10028553S
clip assembly tool	1	FXTXXXXXX10018855S
stanchion grease tool	1	FWTXXXXXXXX018638S
volume reduction spacer mounting tool	1	FXTXXXXXX10028188S
volume reduction spacer positioning tool	1	FXTXXXXXX10028191S
spring unit mounting tool	1	FWTXXXXXX10024414S
special 8 mm internal hex bit	1	FXTXXXXXXXX018482S

Required Tools and Material		Quantity	Article number
reworked 8 mm hex nut		1	FXTXXXXXXXXX018645S
DT Swiss Fork Oil		100 ml	4064XXXXXXXXX000024
		1 l	4064XXXXXXXXX000025
		5 l	4064XXXXXXXXX000027
torque wrench (min. 0.2 Nm / max. 25 Nm)			
Buzzy's Slick Honey		4.7 dl	40341000AD0200001
dust seal kit remote ICP INFO: The kit can be used optional, if the dust seal of the remote control elements is broken.		1 (optional)	FWKXXXXXXXXXX21572S



## 7.1 ASSEMBLING THE DAMPING UNIT

### 7.1.1 INSERTING THE DAMPING UNIT

1. Lubricate the O-rings of the damping unit with DT Swiss Fork Oil.
2. Lubricate the upper part of the stanchion tube with DT Swiss Fork Oil.

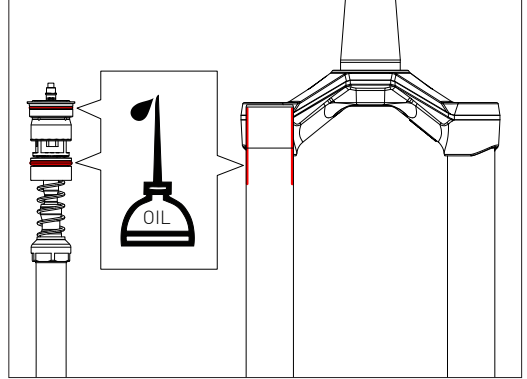

3. Push the damping unit into the stanchion carefully.  
→ Take care not to damage the O-rings.
4. Tighten the damping unit using the tool FXTXXX0XXX011744S and a torque wrench with a torque of 15 Nm.

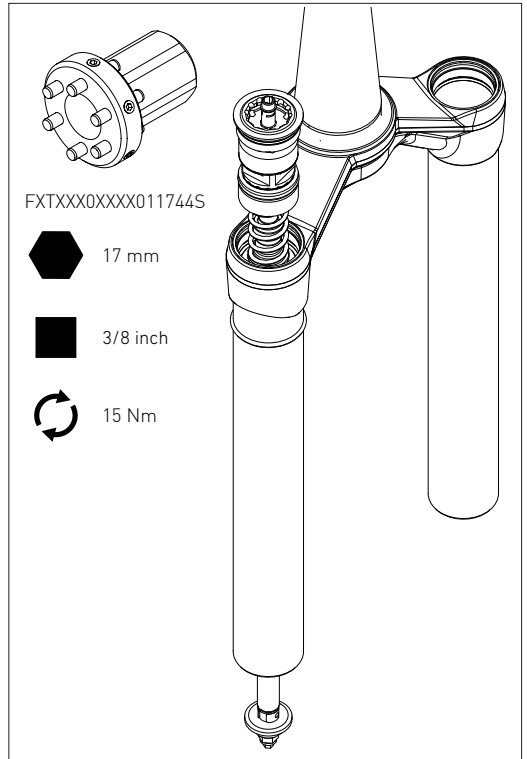

## 7.1.2 BLEEDING THE DAMPING UNIT

1. Put a small piece of hose onto the bleeding tool FWTXXXXXXXXX12840S and a syringe.

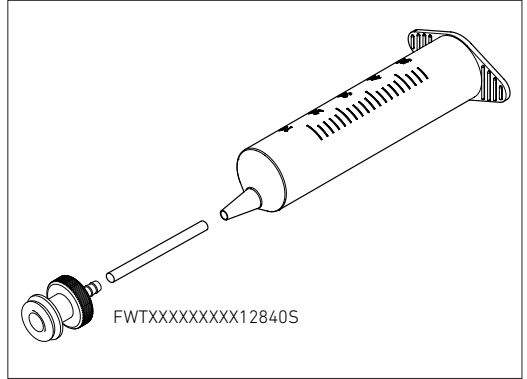

2. Screw the bleeding tool with syringe and hose onto the lockout pin.  
Only screw on the bleeding tool gently until it stops. **DO NOT TIGHTEN!**
3. When the bleeding tool is screwed on fully, turn back the bleeding tool about 70° (= OPEN position).
4. Fill DT Swiss Fork Oil into the syringe.
5. Bleed the damping unit by pulling and pushing the piston rod several times.
  - Refill the syringe, if needed.
  - After the first few strokes of the damping rod, pull at faster speed to get out small bubbles better.
6. Check, if the bleeding was successful by turning the bleeding tool 70° clockwise (= LOCKOUT position) and pushing in the damping rod.
  - There must be no or only a little movement of the damping rod.
  - If the damping rod can be pushed in more than 3 mm, the bleeding procedure must be repeated.
7. Remove the bleeding tool with the syringe.

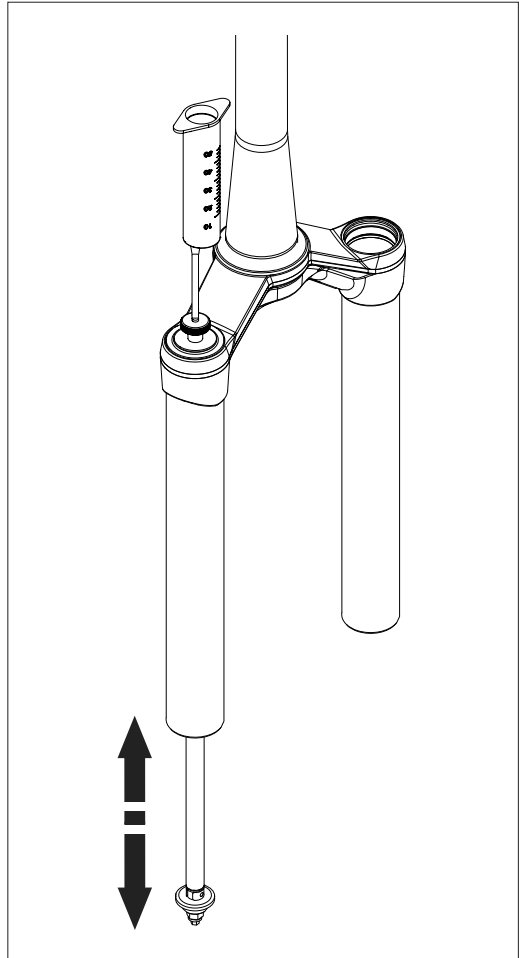

### 7.1.3 MOUNTING THE COMPRESSION PIN

1. Put a new spring and a new ball into a new compression pin.

**INFO:** The compression pin with O-rings, the spring and the ball are part of the seal kit ICP (art. no. FWKXXXXXXXXX28871S). The spring and the ball are also available as a service kit (art. no. FWKXXXXXXXXX20416S).

2. Put the tool FTXXXXXXXXXX018400S onto the assembly.

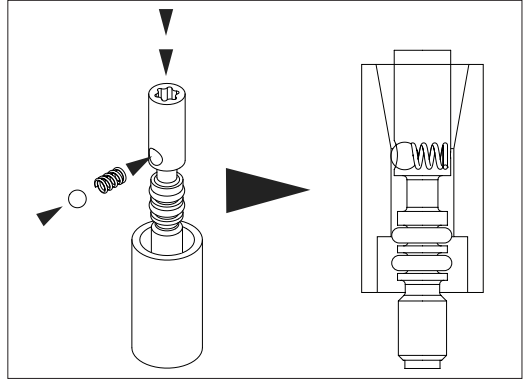

3. Put the assembly onto the lockout pin.

4. Screw in the compression pin completely and then turn it back 5 clicks using a T10 Torx key.

5. Remove the tool FTXXXXXXXXXX018400S.

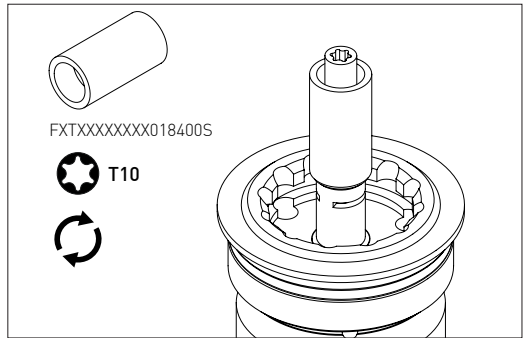

6. Slide the tool FTXXXXXXX10028553S onto the lockout pin, so that the lower part of the tool is positioned at the port for the clip.

7. Put the clip onto the tool and align it with the port.

**INFO:** The clip is part of the seal kit ICP (art. no. FWKXXXXXXXXX28871S). The clip is also available as a service part (art. no. FWKXXXXXXXXX20370S).

8. Push in the clip using the tool FTXXXXXXX10018855S.

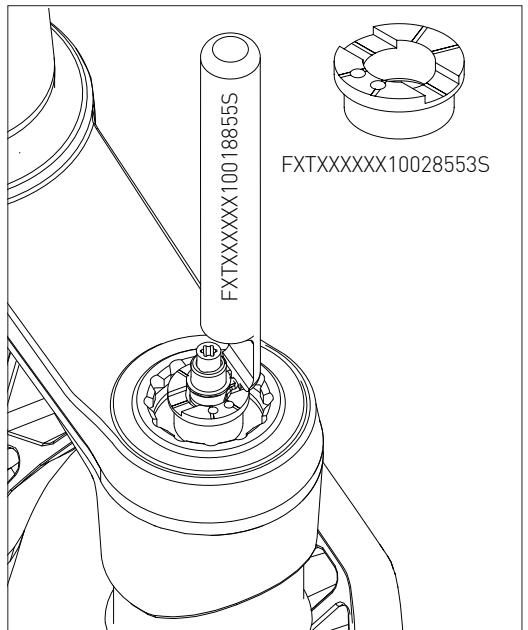

## 7.2 GREASING THE STANCHION TUBE

1. Put Slick Honey onto the foam part of the tool FWTXXXXXXXXX018638S.
2. Slide the tool into the stanchion tube.
3. Remove the tool and check if the inner surface of the stanchion tube is greased evenly.

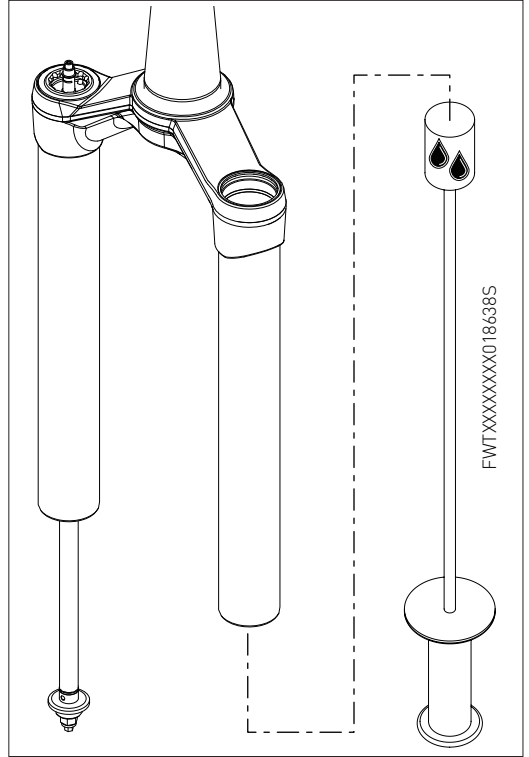

### 7.3 SETTING THE VOLUME REDUCTION SPACER

1. Push the tool FXTXXXXXX10028188S into the stanchion from the bottom.
2. Push in the volume reduction spacer from the bottom using a plastic rod.

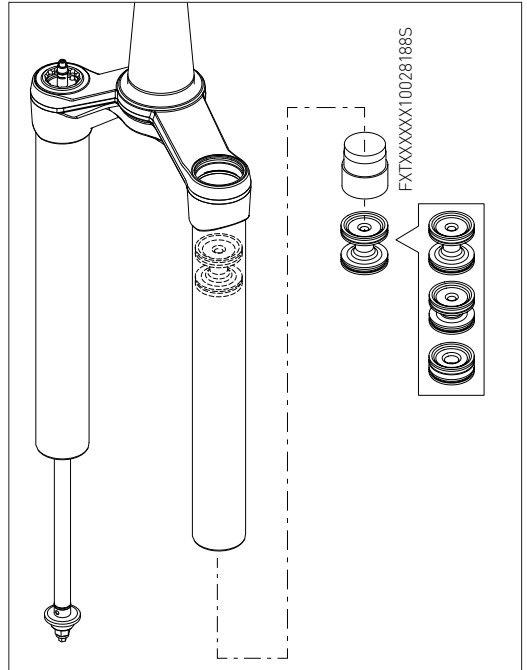

3. Push the tool FXTXXXXXX10028191S into the stanchion from the top.
  - The tool FXTXXXXXX10028191S pushes the volume reduction spacer into the correct position.
  - The distance from the top end of the stanchion to the spacer must be set to 61.5 - 65.5 mm.

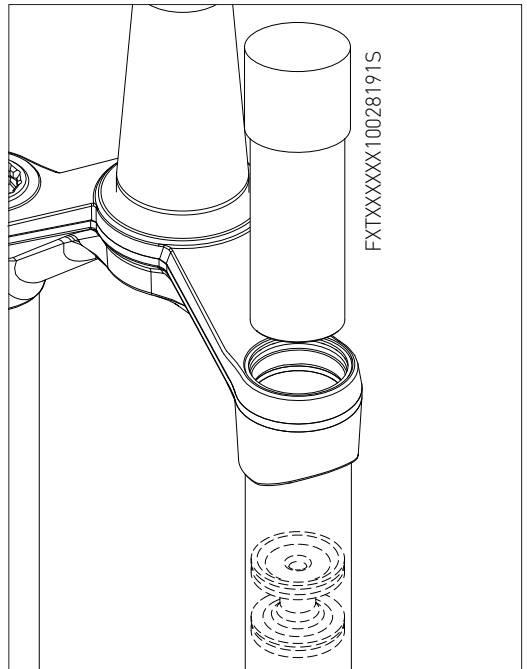

4. Grease the inner surface of the stanchion below the volume reduction spacer again (see „7.2 Greasing the Stanchion Tube“ on page 36). Ensure, that the position of the volume reduction spacer will not be changed.

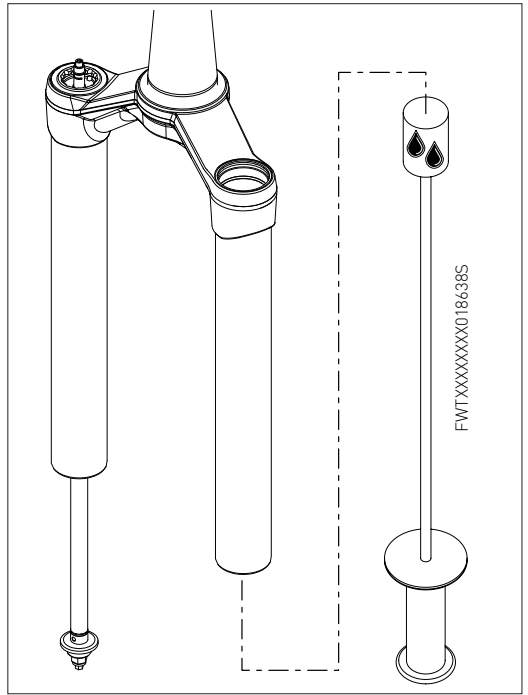

## 7.4 ASSEMBLING THE SPRING UNIT

1. Push the sealhead as far as possible in the direction of the piston.

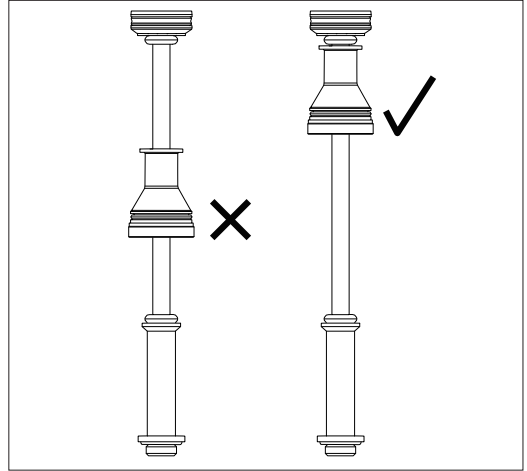

2. Push the bottom out stopper upwards and grease the piston rod in the area of the bottom out stopper with Slick Honey.

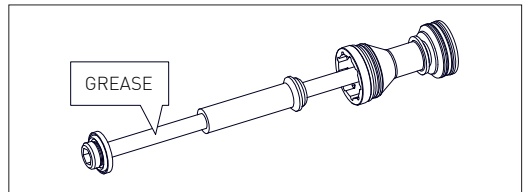

3. Make sure, the O-ring and the quadring are slightly greased.
4. Screw in the spring unit from the bottom using the tool FWTXXXXXX10024414S. Make sure the sealhead is pushed as far as possible in the direction of the piston.

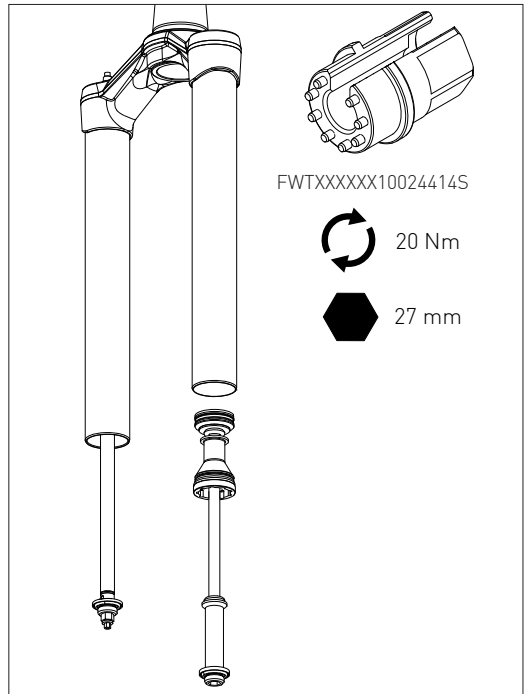

## 7.5 ASSEMBLING THE AIR CHAMBER CAP

1. Ensure that the required amount of volume spacers are mounted on the air chamber cap.



The maximum amount of volume spacers is three! Do not exceed!

2. Check the O-ring of the air chamber cap for damages. Replace the O-ring if necessary. The O-ring is part of the seal kit spring unit FWKXXXXXXXXX28872S.
3. Screw in the air chamber cap using a 15 mm socket and tighten it with a torque of 15 Nm.

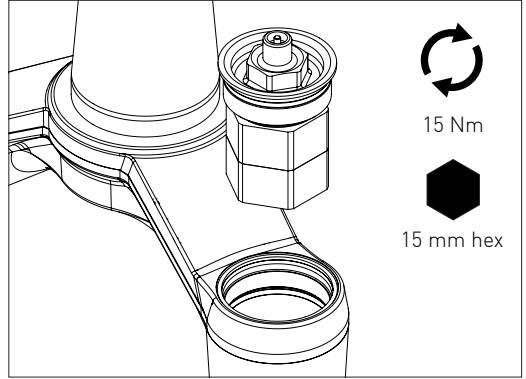

## 7.6 ASSEMBLING THE LOWER UNIT

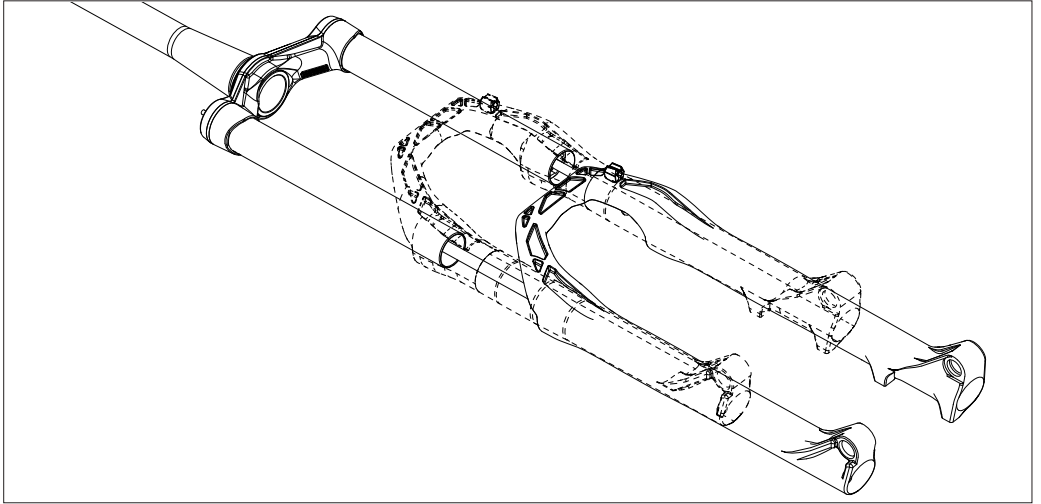

1. Check, if the O-rings of the connectors are still in place. Slightly grease the O-rings with Slick Honey.
2. Slide the SAG O-ring onto the stanchion tube.
3. Slide the lower unit about 2 cm onto the upper unit.



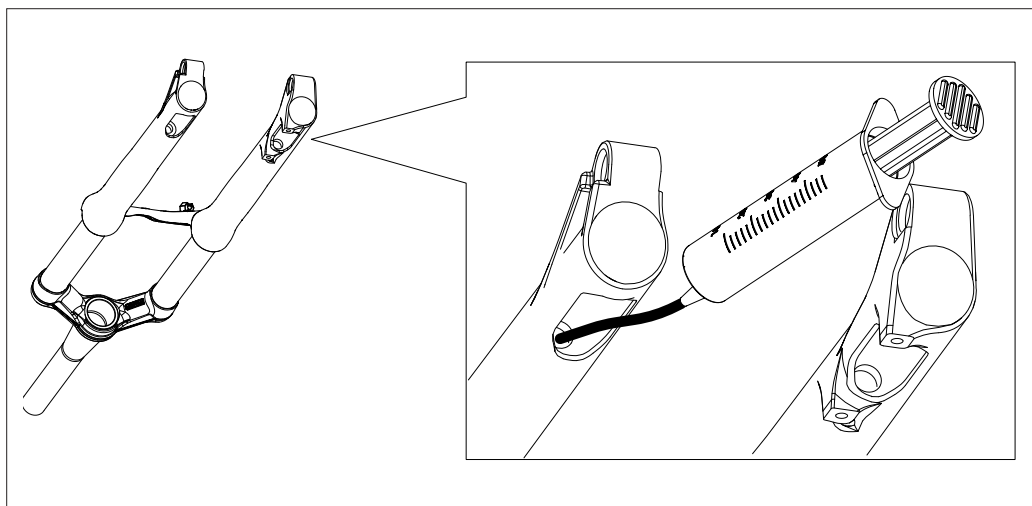

4. Fill 14 ml DT Swiss Fork Oil into the air side of the lower unit.
5. Fill 14 ml DT Swiss Fork Oil into the damping side of the lower unit.
6. Fix the fork 45° - 70° upright for about 60 seconds to allow the bushings to be lubed.
7. Fully slide the lower unit onto the stanchions. Do not compress the piston rod while sliding on the lower unit.

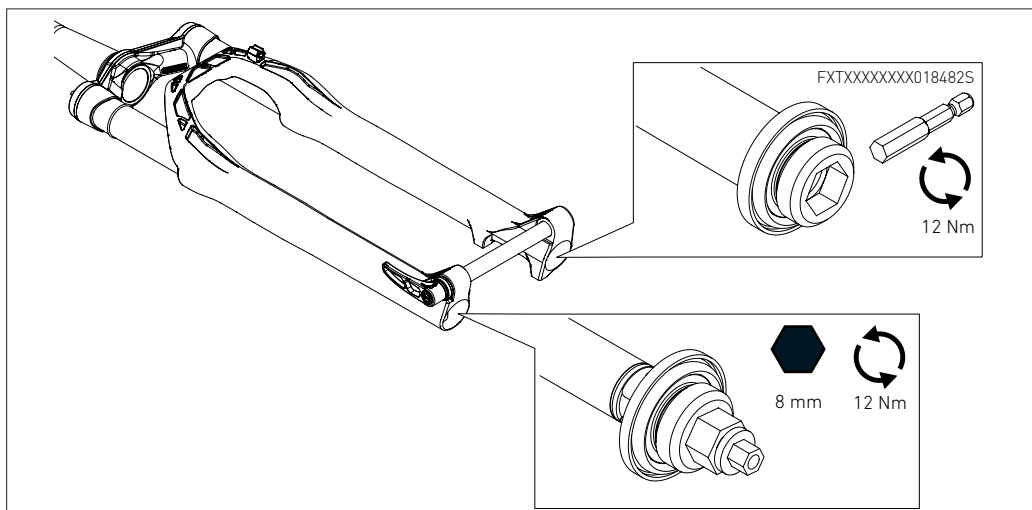

8. Screw in the hexagonal socket screw on the damping side into the lower unit counterclockwise using the special tool FXTXXXXXXXX018482S and tighten it with a torque of 12 Nm.
9. Screw in the hexagonal socket screw on the spring side into the lower unit counterclockwise using an 8 mm hex nut and tighten it with a torque of 12 Nm.

10. Put the rebound adjuster onto the hex of the damping unit.
11. Put Loctite onto the thread of the fixing screw.
12. Hold the rebound adjuster using a 12 mm wrench and screw on the fixing screw of the rebound adjuster using a long 2.5 mm hex key. Tighten the fixing screw with a torque of 1.1 Nm.

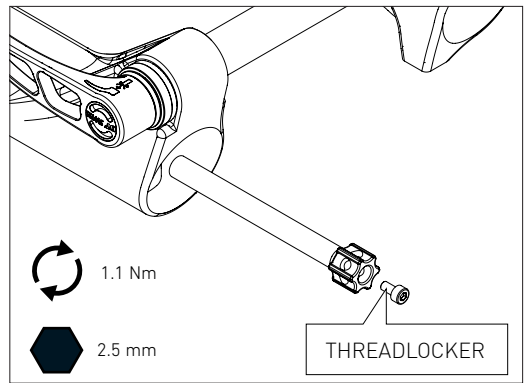

## 7.7 ASSEMBLING THE CONTROL ELEMENTS

### 7.7.1 ASSEMBLING THE REMOTE CONTROL ELEMENTS

1. Ensure that the lockout pin is turned until stop in clockwise direction.
  - Turn the lockout pin if needed.
2. Slightly grease the O-ring and put it into the groove on the top of the damping unit.
  - The O-ring must rest equally in the whole circumference of the groove.
3. Slightly grease the lockout pin.

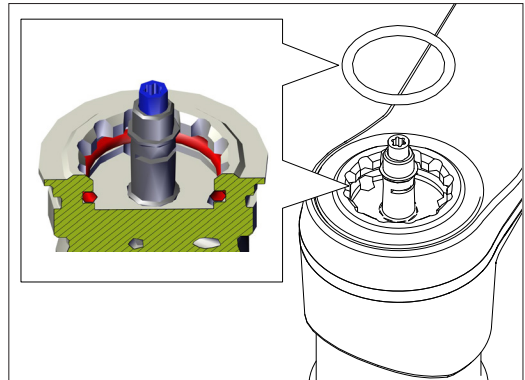

4. Grease the spring and insert it into the cable guide.
  - The horizontally angled arm of the spring must rest in the slot of the cable guide.
5. Push the cable guide with the spring onto the damping unit.
  - If the cable guide cannot be pushed in fully, possibly the O-ring is not positioned correctly (see last step).
  - The cable guide must rest fully on the fork crown.
  - The cable guide must face in ride direction to the middle of the fork without touching the fork crown.

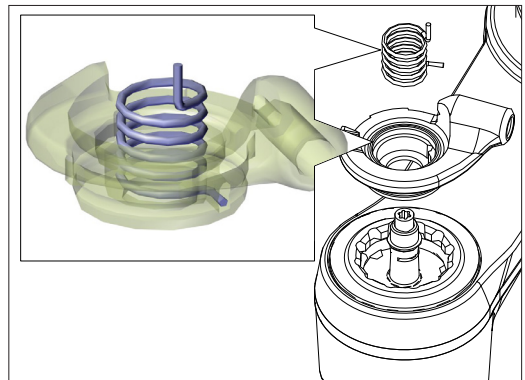

6. Put the dust seal onto the cable guide.

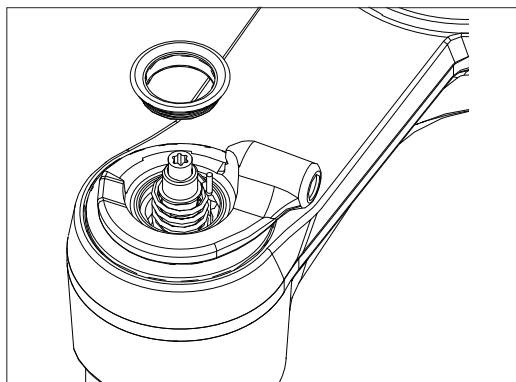

7. Put the end of the spring facing upwards into the bore of the remote wheel.

8. Put the remote wheel onto the lockout pin.

9. Put a 2 mm Allen key into the hex of the cable fixing screw and turn the remote wheel approx. 180° until the remote wheel engages behind the rise of the cable guide.

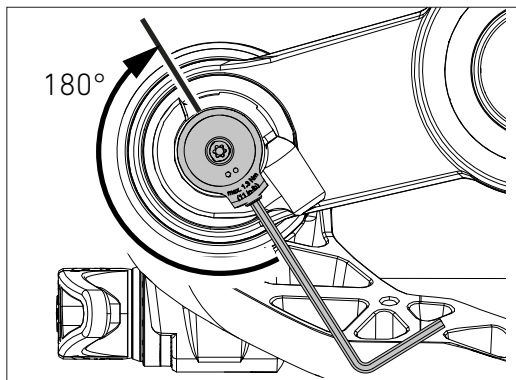

→ Push down the remote wheel while turning.

→ The rise of the cable guide prevents that the remote wheel turns backwards.

10. Push the remote wheel down in the engaged position and hold it in this position.

11. Remove the Allen key.

12. Screw the fixing nut onto the pin by hand.

13. Turn the remote wheel into the lockout position using the short end of an angled 2 mm Allen key.

→ The remote wheel is in the lockout position when it touches the cable stop [see picture].

14. Screw on the fixing nut clockwise using the special tool FXTXXXXXXXX018645S and tighten the fixing nut with a torque of 5 Nm.

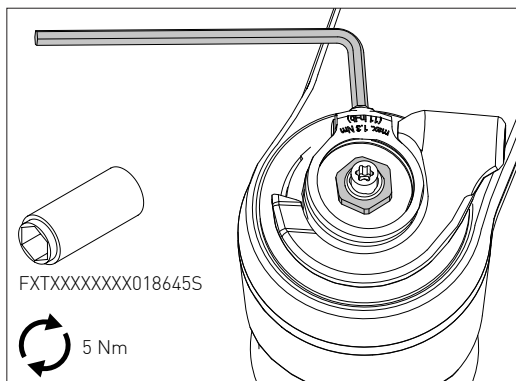

15. Check the correct assembly of the remote wheel: Turn the remote wheel using the short end of an angled 2 mm Allen key.
  - The remote wheel must turn from the left stop to the cable stop.
  - If the remote wheel cannot be turned in this angle, the lockout pin is not positioned correctly. Dismount the remote wheel and position the lockout pin again (see step 1 on page 42).
16. Put on the O-ring into the groove of the remote wheel and pop on the compression cover.

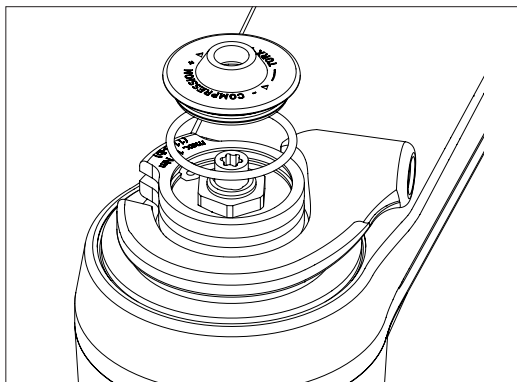

## 7.7.2 ASSEMBLING THE MANUAL CONTROL ELEMENTS

1. Ensure that the lockout pin is turned until stop in clockwise direction.
  - Turn the lockout pin if needed.
2. Put the springs into the index caps.
 

TIP: Put some grease onto the springs so that they stick inside the index caps.
3. Put all three index caps with the springs into the bores of the damping unit.
4. Put on the raster and turn it clockwise until it comes to the last of the three index positions. One of the three pins must match in the notch direction of the raster.

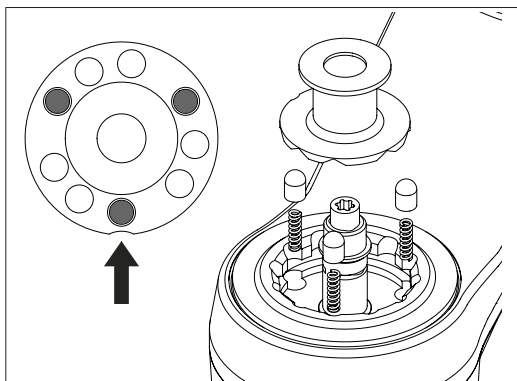

5. Put on the O-ring and the lever.

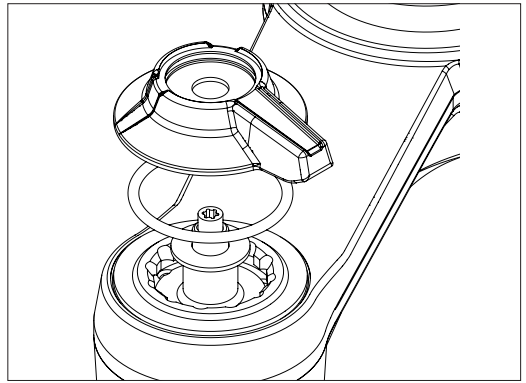

6. Screw on the fixing nut by hand.

7. Hold the lever in position «LOCK» and tighten the fixing nut with 5 Nm using the tool FXTXXXXXXXXX018645S.

8. Check the position of the lever.

- In the position «DRIVE», the lever must face in riding direction.
- The lever must lock in the three positions.

9. Check the damping function of the positions «OPEN», «DRIVE» and «LOCK» by compressing the fork.

10. Put on the O-ring into the groove of the remote wheel and pop on the compression cover.

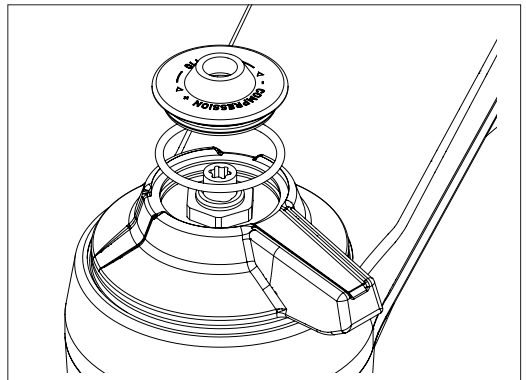
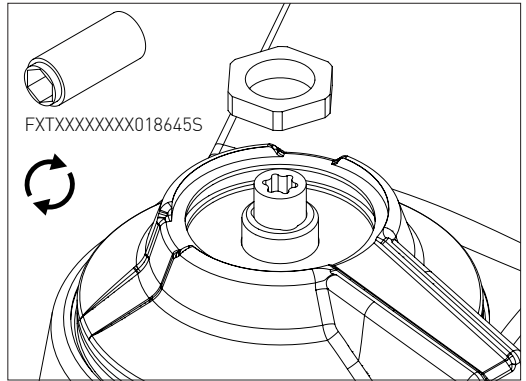

## Closing Steps

Check all functions of the fork

## Link

**DT SWISS AG**

Längfeldweg 101  
CH - 2504 Biel/Bienne  
info.ch@dtswiss.com

**DT SWISS, INC.**

2493 Industrial Blvd.  
USA - Grand Junction, CO 81505  
info.us@dtswiss.com

**DT SWISS (FRANCE) S.A.S.**

Parc d'Activites de la Sarrée  
Route de Gourdon  
F - 06620 Le Bar sur Loup  
info.fr@dtswiss.com

**DT SWISS ASIA LTD.**

No.5, Jingke 5th Rd., Nantun District  
Taichung City 408  
Taiwan (R.O.C.)  
info.tw@dtswiss.com

**DT SWISS DEUTSCHLAND GmbH**

Albert-Einstein-Strasse 3  
59302 Oelde  
Germany  
info.de@dtswiss.com

**DT SWISS POLSKA Sp. z o.o.**

ul. Towarowa 36  
PL-64-600 Oborniki  
Poland  
info.pl@dtswiss.com

Subject to technical alterations, errors and misprints excepted.

All rights reserved.

© by DT SWISS AG

[www.dtswiss.com](http://www.dtswiss.com)

FXD10000002821S