

DT SWISS

SPLINE WHEELS
TECHNICAL MANUAL

V2022.03

1.	GENERAL	3
1.1	Validity.....	3
1.2	Safety	3
1.3	Target group.....	3
1.4	Layout.....	3
1.5	DT Swiss manual concept	3
1.6	General Maintenance Information	4
1.7	Environmental protection.....	4
1.8	Exclusion of liability.....	4
1.9	Warranty.....	4
2.	CONVERTING THE END CAPS.....	5
2.1	Converting the end caps on the front wheel [plugged-in end caps]	5
2.2	Changing the end caps on the front wheel [pressed-on end caps].....	7
2.3	Converting the end caps on the rear wheel	11
3.	HUB MAINTENANCE	13
3.1	Service intervals	13
3.2	Safety	13
3.3	Rear hub maintenance with Ratchet and Ratchet LN system.....	14
3.4	Maintenance of the rear wheel hub with Ratchet EXP® System	20
4.	MAINTENANCE OF THE WHEEL.....	26
4.1	Service intervals	26
4.2	Safety	26
4.3	Changing a spoke: Basics	27
4.4	PHR System: Basics.....	29
4.5	Replacing a spoke with crossed lacing.....	30
4.6	Replacing a spoke with radial lacing	33
5.	TROUBLE SHOOTING.....	36
5.1	Trouble Shooting Hubs.....	36
5.2	Trouble Shooting Wheels	37
6.	TECHNICAL DATA	38
6.1	Spoke tension	38
6.2	Tolerances.....	38

1. GENERAL

1.1 VALIDITY

This manual describes the component specified on the front page and the footer. This manual is valid for the design of the product as of 21.03.22. Deviations are possible and all items are subject to technical changes.

1.2 SAFETY

The safety instructions are classified as follows:



DANGER

...indicates a hazardous situation that, if not avoided, will result in death or serious injury.



CAUTION

... indicates a hazard with a medium level of risk which, if not avoided, may result in minor or moderate injury.



NOTE

... indicates a potentially hazardous situation that may result in damage to property.

1.3 TARGET GROUP

This manual is intended for the user of the component and dealers. This manual offers the experienced user the possibility to carry out minor service work himself. If you have any doubts about your own abilities, you should definitely contact an expert or a DT Swiss Service Center.

Any warranty claims will lapse if work is not carried out properly.

1.4 LAYOUT

The cover page and the footing provide information about the type of product and manual as well as the version of the manual. The DT Swiss contact details can be found on the back. A list of all DT Swiss service centers can be found at www.dtswiss.com.

This manual is intended for being printed as an A5 booklet. Only print this manual if electronic usage is not possible.

1.5 DT SWISS MANUAL CONCEPT

The DT Swiss manuals are split into the following types of manuals:

- User Manual: Information for the end user on how to install and use the component.
- Technical Manual: Detailed information for the end user and the dealer on how to maintain the component, spare parts and technical data.

1.6 GENERAL MAINTENANCE INFORMATION

Unless otherwise specified, moving parts, threads, O-rings and sealings must be greased before assembly.

CLEANING

For an optimal result of the maintenance works, every component that will be disassembled must be cleaned. Only use cleaners and degreasers which do not damage the components. Especially the cleaning of O-rings and sealings requires mild cleaners. Observe the instructions for use of the respective cleaner.

DT Swiss recommends the following cleaners:

- Motorex Rex
- Motorex Swissclean
- Motorex OPAL 2400, 3000 OPAL, OPAL 5000

Use soap water or similar mild cleaners for external cleaning.

TOOLS

To ensure a damage-free mounting and dismounting of the components, only use the tools which are mentioned in this manual. Special tools are indicated at the beginning of a chapter in the table "Required material".

The use of different tools is at the discretion of the user. If components are damaged by the usage of differing tools, the user is liable.

DT Swiss special tools are precision tools. Damage-free mounting and dismounting of the components can only be ensured if the tools are working properly and if the condition of the tools are perfect. Always keep the tools in their original packaging or adequate devices to prevent damage.

1.7 ENVIRONMENTAL PROTECTION

The statutory regulations shall apply. Whenever possible, avoid creating waste. Waste, especially carbon, lubricants, cleaners and any other fluids must be disposed in an environmentally compatible manner. Only print this manual if electronic usage is not possible.

1.8 EXCLUSION OF LIABILITY

The activities listed in this manual may only be carried out by persons with sufficient specialist knowledge. The user is liable for any damage or consequential damage caused by wrongly maintained or installed components. If you have doubts, please contact an expert or your region's DT Swiss pro level service center.

1.9 WARRANTY

Warranty conditions, see www.dtswiss.com

2. CONVERTING THE END CAPS

2.1 CONVERTING THE END CAPS ON THE FRONT WHEEL [PLUGGED-IN END CAPS]

OVERVIEW

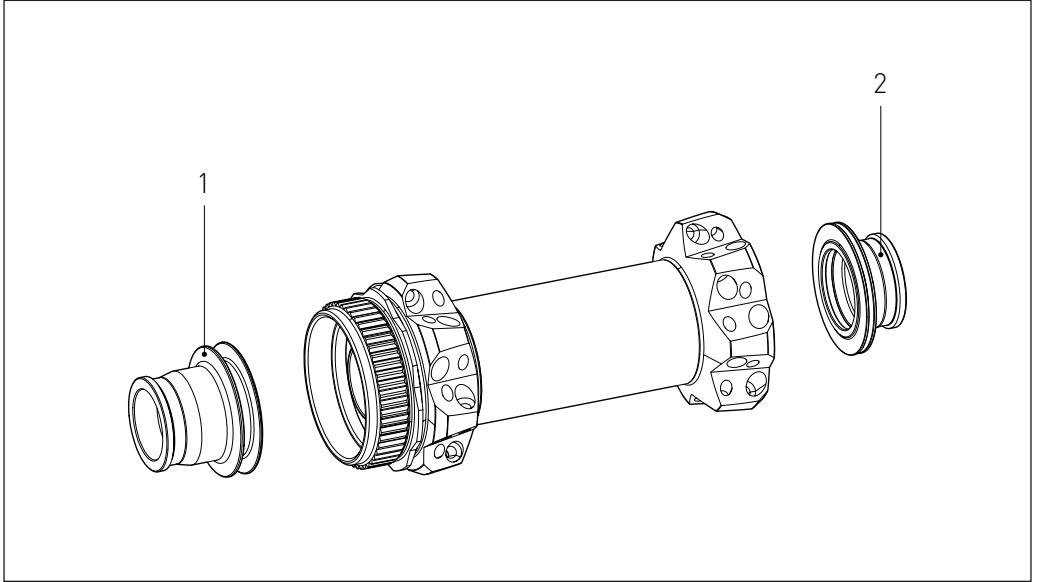

1 end cap non drive side

2 end cap drive side

You can find the possible conversion options for your wheel at dtswiss.com/en/support/product-support.

REQUIRED WEARING PARTS AND MATERIALS

Wearing parts / Materials	Specification	Quantity	Article number
DT Swiss universal grease		20 g	HXTXXX00NMG20S

1. Pull off both end caps by hand.

If the end caps cannot be pulled off by hand, clamp the end caps carefully into a vise with ground clamping jaws and pull the hub / wheel upwards.



2. Clean both end caps and ball bearings with a dry cloth.



3. Grease the bearings and the inner surface of both end caps.



4. Put on the left and the right end cap.
→ The shorter end cap must be placed on the drive side.
5. Push in end caps by hand.



2.2 CHANGING THE END CAPS ON THE FRONT WHEEL [PRESSED-ON END CAPS]

OVERVIEW

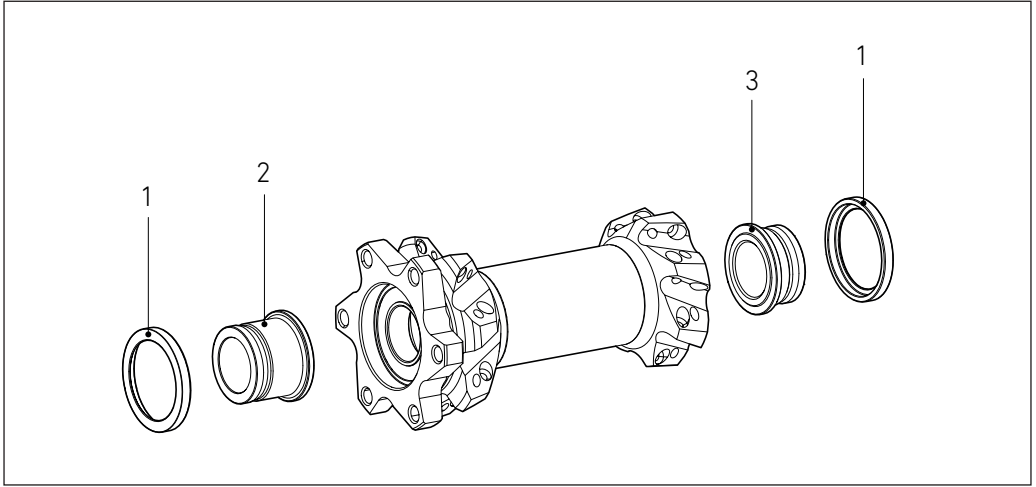

1 cover

2 end cap non drive side

3 end cap drive side

You can find the possible conversion options for your wheel at dtswiss.com/en/support/product-support.

REQUIRED TOOLS

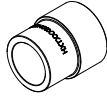
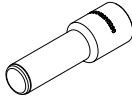
Tools	Specification	Quantity	Article number
Tool set 350 Ø15 mm, includes		1	HWTXXX00N5290S
<ul style="list-style-type: none"> installation cylinder Ø28 mm 		1	
<ul style="list-style-type: none"> mounting pin Ø15 mm 		1	

MATERIALS NEEDED

Material	Specification	Quantity	Article number
DT Swiss universal grease		20 g	HXTXXX00NMG20S

REMOVING THE END CAPS



NOTE

RISK OF DAMAGE TO THE END CAPS AND THE BALL BEARINGS!

The mounting pin must not touch the ball bearing while the end caps are being levered out.

1. Insert the mounting pin into one of the end caps.
→ Risk of damage: see note!
2. Push the mounting pin downwards (see picture).



3. Remove end cap and cover.
4. Repeat previous steps at the second end cap.



5. Clean both end caps and ball bearings with a dry cloth.



MOUNTING END CAPS Ø 15 MM

1. Grease the bearings and the inner surface of both end caps.



2. Fit one of the two end caps and the cover onto the installation cylinder.

- end cap non drive side: Push the end cap with cover onto the small diameter of the installation cylinder.
- end cap drive side: Fit the end cap with cover onto the large diameter of the installation cylinder.

3. Insert the mounting pin into the installation cylinder.



4. Tap the cover onto the hub shell.

- The longer end cap must be placed on the non drive side.

5. Repeat the procedure for the second end cap.



MOUNTING END CAPS Ø 12 MM AND Ø 5 MM

When converting to end caps for Ø 12 mm and Ø 5 mm axes, plug-in end caps are fitted instead of the pressed-on end caps.

1. Grease the bearings and the inner surface of both end caps.
2. Put on the left and the right end cap.
→ The shorter end cap must be placed on the drive side.
3. Push in end caps by hand.



2.3 CONVERTING THE END CAPS ON THE REAR WHEEL

OVERVIEW

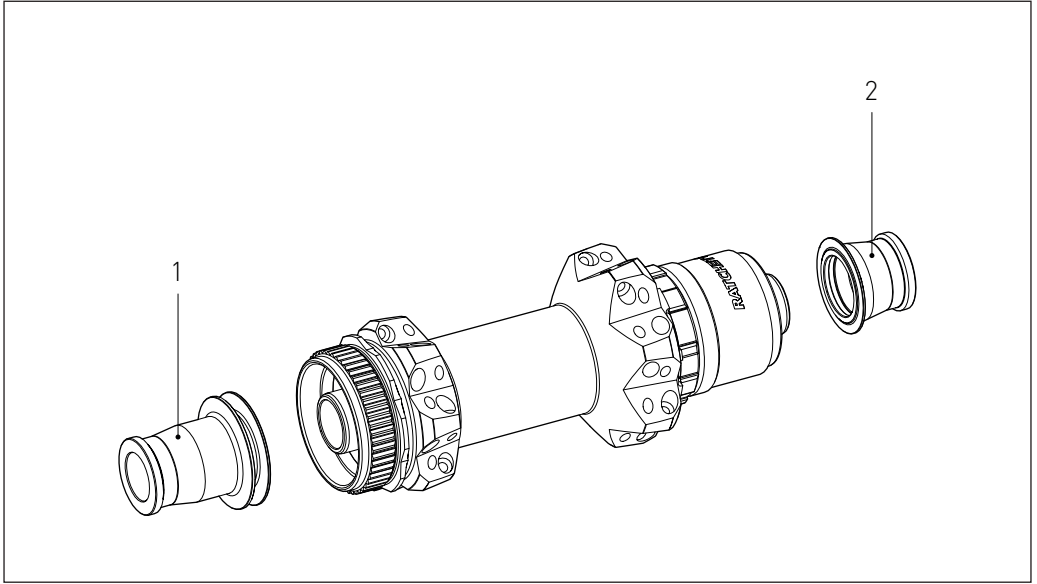

1 end cap non drive side

2 end cap drive side

You can find the possible conversion options for your wheel at dtswiss.com/en/support/product-support.

REQUIRED WEARING PARTS AND MATERIALS

Wearing parts / Materials	Specification	Quantity	Article number
DT Swiss universal grease		20 g	HXTXXX00NMG20S

1. Pull off both end caps by hand.

If the end caps cannot be pulled off by hand, clamp the end caps carefully into a vise with ground clamping jaws and pull the hub / wheel upwards.



2. Clean both end caps and ball bearings with a dry cloth.



3. Grease both bearings and the inner side of both end caps.



4. Put on the left and the right end cap.
→ The shorter end cap must be placed on the drive side.
5. Push in end caps by hand.



3. HUB MAINTENANCE

This chapter describes a small hub service. This includes:

- End caps: Disassembling, cleaning, greasing and assembling
- Freewheel body: Disassembling, cleaning, greasing and assembling
- Freewheel system: Cleaning and degreasing.

The description of a full hub service can be found in the technical manual of the respective hubs at dtswiss.com.

3.1 SERVICE INTERVALS

The following regular maintenance and care work is recommended by DT Swiss:

Task	Interval
Small Service <ul style="list-style-type: none">• Under normal operating conditions• in extreme operating conditions (frequent riding in rain, mud, snow)	6 months as required
Full hub service (see Technical Manual at dtswiss.com) <ul style="list-style-type: none">• Under normal operating conditions• in extreme operating conditions (frequent riding in rain, mud, snow)	12 months as required
Check the hub for damage	before and after each ride
Clean with soft cloth and a suitable cleaner (see "Cleaning" on page 4). Do not use high pressure cleaners or aggressive cleaning agents!	after each ride

3.2 SAFETY



DANGER

DANGER TO LIFE DUE TO INCORRECT MAINTENANCE AND INCORRECT SPARE PARTS!

Unpredictable malfunctions can occur due to incorrect maintenance, incorrect installation or incorrect spare parts.

- Maintenance may only be carried out by experienced specialists.
- Use only original DT Swiss spare parts or spare parts approved by DT Swiss.
- In cases of doubt, please contact a DT Swiss Service Center.

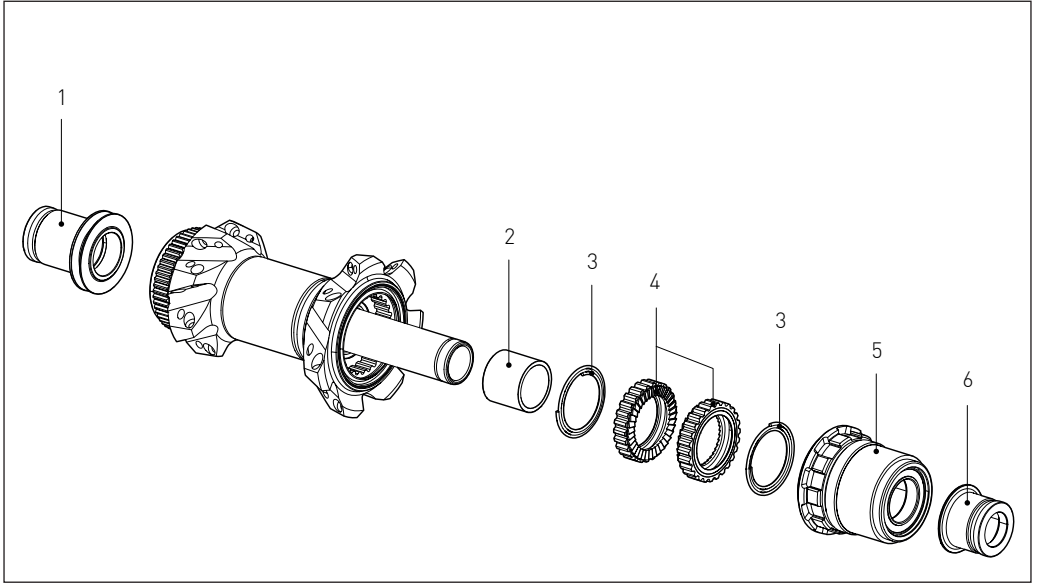

3.3 REAR HUB MAINTENANCE WITH RATCHET AND RATCHET LN SYSTEM

OVERVIEW



1	end cap non drive side	4	ratchet
2	spacer	5	freewheel body
3	spring	6	end cap drive side

REQUIRED WEARING PARTS AND MATERIALS

Wearing parts / Materials	Specification	Quantity	Article number
DT Swiss universal grease		20 g	HXTXXX00NMG20S
DT Swiss special grease		20 g	HXT10032508S

REMOVING END CAPS, FREEWHEEL BODY AND FREEWHEEL SYSTEM

1. Pull off both end caps by hand.

If the end caps cannot be pulled off by hand, clamp the end caps carefully into a vise with ground clamping jaws and pull the hub / wheel upwards.



2. Pull the freewheel body off the hub.



3. Remove springs, ratchets and spacer from the hub.



CLEANING AND CHECKING ALL PARTS

1. Thoroughly clean all parts of the hub. The existing grease must be completely removed from the hub body and from the ratchets.
2. Check the ratchets for wear.

The wear of the ratchets usually starts at the outer circumference and shows itself by strongly flattened edges with uneven wear.

In case of heavy wear, the ratchets must be changed immediately.



3. Check the freewheel body for damages.
→ Grooves from the cassette are no damages. These are normal signs of usage.
4. Remove bad notches on the freewheel body using a file.
5. Clean the freewheel body. Metal chips and metal particles must be removed completely.



DANGER

RISK OF INJURY DUE TO LIMITED FREEWHEEL FUNCTION DUE TO INCORRECT LUBRICATION!

If too much grease is applied on the ratchets, the actuation of the ratchets may not work. The ratchets may slip during pedaling.

- Only apply a thin, even layer of grease.
- Only use the red DT Swiss special grease.

1. Apply DT Swiss special grease evenly to the outer and the inner tothing of the ratchets using a fine brush.
→ For an optimal functionality of the freewheel system, a thin layer of grease is sufficient.



2. Grease the teeth of the freewheel body and the ring nut with DT Swiss special grease.



3. Attach the spacer and the first spring.
→ The spring must rest on the hub with its large diameter.



4. Attach both ratchets and the second spring.
5. The spring must rest with its small diameter on the ratchet.



PUTTING ON THE FREEWHEEL BODY AND THE END CAPS

1. Put the freewheel body onto the hub.
2. Check if the freewheel body can be turned and if the ratchets are engaging.



3. Grease the bearings and the inner surface of both end caps.



4. Put on the left and the right end cap.
→ The shorter end cap must be placed on the drive side.
5. Push in end caps by hand.



CHECK THE FUNCTIONALITY

1. Turn the freewheel body in both directions.
→ The freewheel body can be turned counterclockwise easily.
The ratchets engage audibly and perceptibly.
→ The freewheel body cannot be turned clockwise.
2. Check the tightness of the end caps.
→ The end caps are firmly seated on the axle and are fully pushed on.

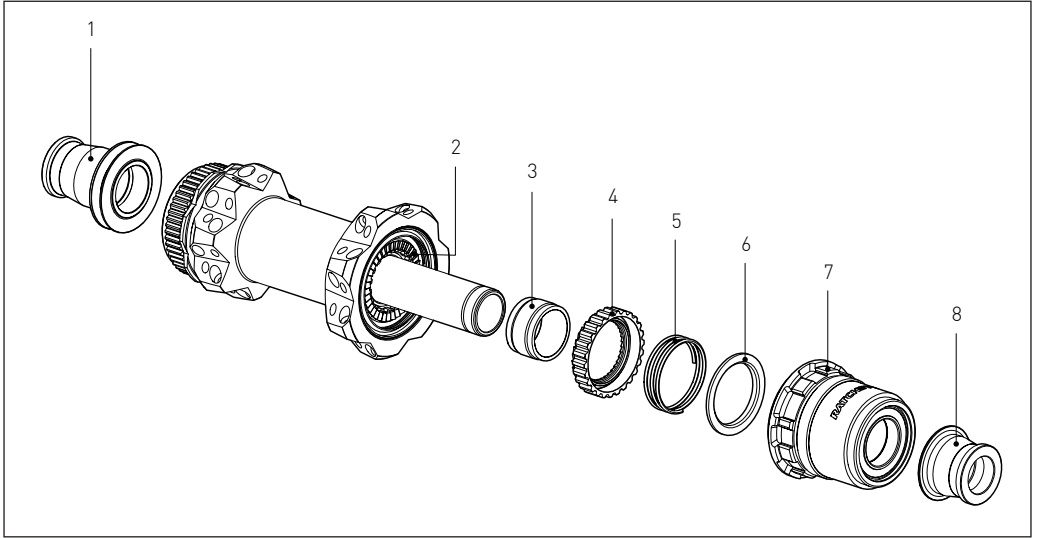

3.4 MAINTENANCE OF THE REAR WHEEL HUB WITH RATCHET EXP® SYSTEM

OVERVIEW



1	end cap non drive side	4	loose ratchet	7	freewheel body
2	threaded ratchet	5	spring	8	end cap drive side
3	spacer	6	washer		

REQUIRED WEARING PARTS AND MATERIALS

Wearing parts / Materials	Specification	Quantity	Article number
DT Swiss universal grease		20 g	HXTXXX00NMG20S
DT Swiss special grease		20 g	HXT10032508S

REMOVING END CAPS, FREEWHEEL BODY AND FREEWHEEL SYSTEM

1. Pull off both end caps by hand.

If the end caps cannot be pulled off by hand, clamp the end caps carefully into a vise with ground clamping jaws and pull the hub / wheel upwards.



2. Pull the freewheel body off the hub.



3. Remove springs, ratchets and spacer from the hub.



CLEANING AND CHECKING ALL PARTS

1. Thoroughly clean all parts of the hub. The existing grease must be completely removed from the hub body and from the ratchets.
2. Check the ratchets for wear.

The wear of the ratchets usually starts at the outer circumference and shows itself by strongly flattened edges with uneven wear.

In case of heavy wear, the ratchets must be changed immediately.



3. Check the freewheel body for damages.
→ Grooves from the cassette are no damages. These are normal signs of usage.
4. Remove bad notches on the freewheel body using a file.
5. Clean the freewheel body. Metal chips and metal particles must be removed completely.



DANGER

RISK OF INJURY DUE TO LIMITED FREEWHEEL FUNCTION DUE TO INCORRECT LUBRICATION!

If too much grease is applied on the ratchets, the actuation of the ratchets may not work. The ratchets may slip during pedaling.

- Only apply a thin, even layer of grease.
- Only use the red DT Swiss special grease.

1. Apply DT Swiss special grease with a fine brush evenly on the face teeth of the ratchets.
→ For an optimal functionality of the freewheel system, a thin layer of grease is sufficient.
2. Grease the teeth of the freewheel body with DT Swiss special grease.
3. Attach the spacer, the ratchet and the spring.



PUTTING ON THE FREEWHEEL BODY AND THE END CAPS

1. Put the freewheel body onto the hub.
2. Check if the freewheel body can be turned and if the ratchets are engaging.



3. Grease both bearings and the inner side of both end caps.



4. Put on the left and the right end cap.
→ The shorter end cap must be placed on the drive side.
5. Push in end caps by hand.



CHECK THE FUNCTIONALITY

1. Turn the freewheel body in both directions.
 - The freewheel body can be turned counterclockwise easily.
The ratchets engage audibly and perceptibly.
 - The freewheel body cannot be turned clockwise.
2. Check the tightness of the end caps.
 - The end caps are firmly seated on the axle and are fully pushed on.

4. MAINTENANCE OF THE WHEEL

This chapter describes activities that affect the entire wheel:

- Truing the wheel
- Replacing a spoke

4.1 SERVICE INTERVALS

The following regular maintenance and care work is recommended by DT Swiss:

Task	Interval
Check the spoke tension, dish and wear of the wheel.	10 operating hours
Spoke tensions and tolerances, see "6. Technical data" on page 38	
Check the wheel for damage	before and after each ride
Clean with soft cloth and a suitable cleaner.	after each ride
Do not use high pressure cleaners or aggressive cleaning agents!	
Check that the fork is correctly fastened.	before each ride
Rim brake wheels: <ul style="list-style-type: none">• Remove any contaminations (especially oil and traces of grease) from the brake surfaces• Check the degree of wear of the brake pads• Remove any entrenched impurities (grit, swarf, etc.)• Check the degree of wear on the braking surfaces of the rim. If in doubt, or if there is any visible wear, have it checked by an expert.	before each ride

4.2 SAFETY



DANGER

DANGER TO LIFE DUE TO INCORRECT MAINTENANCE AND INCORRECT SPARE PARTS!

Unpredictable malfunctions can occur due to incorrect maintenance, incorrect installation or incorrect spare parts.

- Maintenance may only be carried out by experienced specialists.
- Use only original DT Swiss spare parts or spare parts approved by DT Swiss.
- In cases of doubt, please contact a DT Swiss Service Center.

4.3 CHANGING A SPOKE: BASICS

HOW TO LOOSEN / TIGHTEN A NIPPLE?

The nipple can be screwed on in two ways:



With the help of the DT Swiss Spokey, the nipple can be turned on the inside of the rim. This method is particularly useful for:

- Small corrections of the spoke tension
- Repairs "on trail"
- Corrections / repairs to a spoke where the nipple does not need to be replaced.

Neither the tire nor the Tubeless Ready Tape must be removed. The disadvantage of this method is that traces of the tool can often be seen on the nipple.



red / square

Item No:
TTSXXXXR05633S



With the help of the DT Swiss nipple key, the nipple can be turned on the outside of the rim. This is the common method for:

- More extensive work on several spokes.
- All work where the nipple must be replaced.

After completion of the work, a new Tubeless Ready Tape must be installed.

Three different nipple keys are available:



red / square

Item No: TTSXXXXR05631S



black / Torx

Item No: TTSXXXXS05630S



blue / hex

Item No: TTSXXXXB05632S

HOW TO HOLD A SPOKE?

Spokes must be held during loosening and during tensioning. Depending on the spoke and the type of tool used, there are different methods:

Round spokes



Round spokes must be held during tensioning and loosening of the nipple. This can be done with a small flat nose pliers or similar tool. It is important here to make sure that the spoke is not damaged and not scratched.

Flat spokes



Flat spokes must also be held while the nipple is tightened and loosened. This must be done with a spoke holder depending on the spoke type. It is important here to ensure that the spoke holder is pushed as far as possible in the direction of the nipple.

There are two different spoke holders available:



red / spoke holder Aero 0.8 - 1.0 mm (DT aerolite®)

Item No.: TTSXXXXR05641S



black / spoke holder Aero 1.0 - 1.3 mm

(DT aero comp®, DT new aero®, DT aero speed®)

Item No.: TTSXXXXS05644S

4.4 PHR SYSTEM: BASICS

Some of the DT Swiss wheels are equipped with the PHR system. The DT Swiss PHR (PRO HEAD® REINFORCEMENT) system consists of a washer and a specially shaped nipple. The shape of the washer (PHR washer) acts as a ball joint and perfectly aligns the specially developed DT Squorx Pro Head® ball head nipple in the direction of pull, minimizing the risk of spoke breakage.

MOUNTING OF THE PHR SYSTEM

1. Grease the contact surface of the PHR washer and Squorx nipple with universal grease.
2. Slide the PHR washer onto the Squorx nipple. See figure for orientation.
3. Push the spoke through hub and rim.
4. Screw the Squorx nipple onto the spoke.
5. Check the alignment of the PHR washer. The bend of the PHR washer (2) must be within the radius of the rim (1).

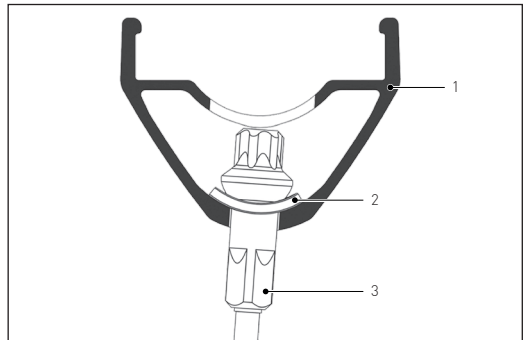
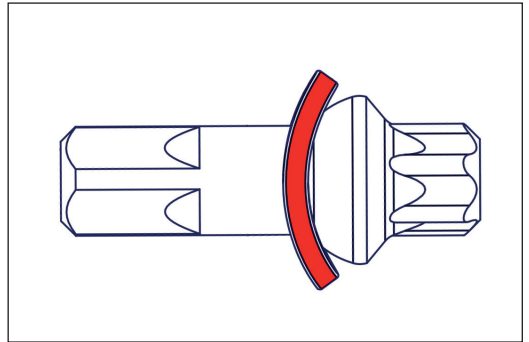
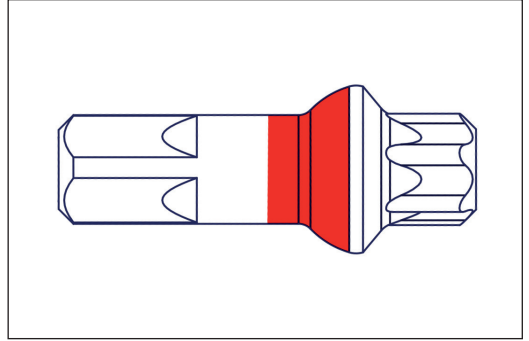

4.5 REPLACING A SPOKE WITH CROSSED LACING

OVERVIEW

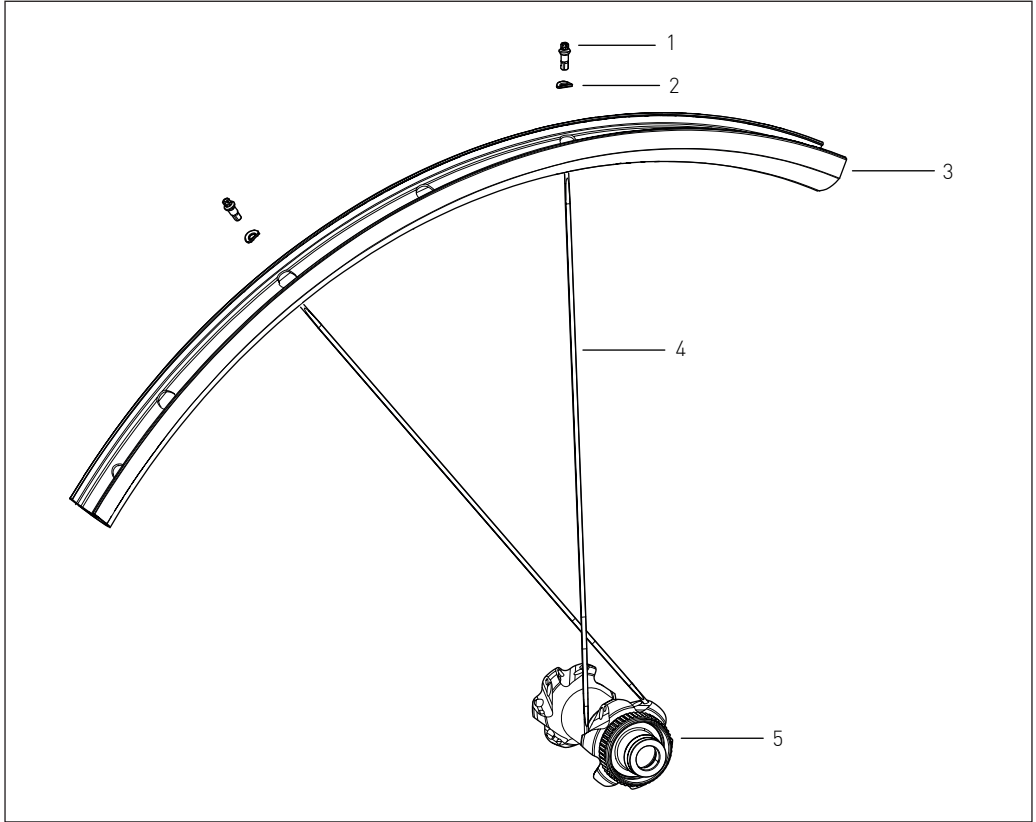

1	nipple	4	spoke
2	PHR washer*	5	hub
3	rim		

*Not all wheels are equipped with PHR washers.

REQUIRED TOOLS

Tools	Specification	Quantity	Article number
see "4.3 Changing a spoke: Basics" on page 27			

REMOVING THE SPOKE TO BE REPLACED

1. Put the wheel in the truing stand.



As a basis for the following steps, it is assumed that the spoke is broken. If the spoke to be replaced is still intact, it can be cut with a cutter or similar.

2. Cut spoke with a cutter if necessary:
 - a. Release the spoke using a screw clamp.
 - b. Cut the spoke carefully.
 - c. Remove the screw clamp.



3. Check if there is a washer (PHR washer) on the nipple.
4. Take the spoke with the nipple out of the rim.
 - If there is a PHR washer: Take care that the washer does not fall into the rim profile.



Only for spokes in the inner spoke holes of the hub flange:

5. Fully loosen the spoke (green) opposite the spoke head of the spoke (red) that needs to be replaced.

TIP: Mark the spokes with a piece of tape.

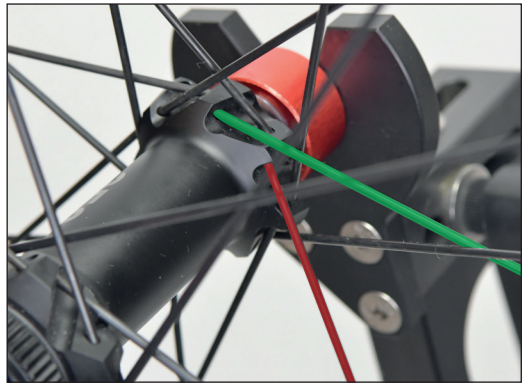

Only for spokes in the inner spoke holes of the hub flange:

6. Push the opposite spoke (green) slightly to the side and unthread the spoke to be changed (red). If the spoke cannot be pushed out of the hub flange, the spoke crossing the opposite spoke and the spoke to be changed (blue) can also be loosened.

7. Remove the spoke.



8. Push the new spoke through the spoke hole in the hub and insert the spoke through the spoke hole in the rim.

→ Observe the correct spoke crossings.

9. Lightly grease the nipple, put the PHR Washer on the nipple and screw the nipple onto the spoke ("4.3 Changing a spoke: Basics" on page 27).

10. True the wheel.

4.6 REPLACING A SPOKE WITH RADIAL LACING

OVERVIEW

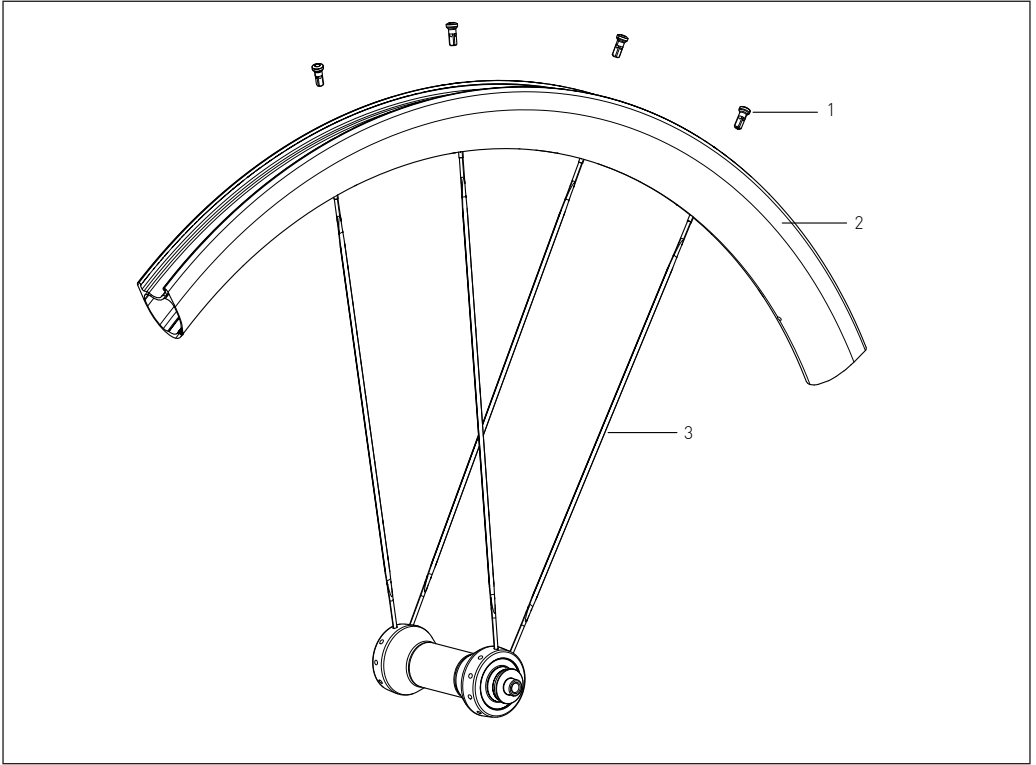

1	nipple
2	rim
3	spoke

REQUIRED TOOLS

Tools	Specification	Quantity	Article number
see "4.3 Changing a spoke: Basics" on page 27			

REMOVING THE SPOKE TO BE REPLACED

1. Remove end cap by hand.



2. Broken spoke: Remove the spoke with nipple and PHR washer from the rim.

3. Intact spoke: Unscrew the nipple [see "4.3 Changing a spoke: Basics" on page 27].



4. Remove the spoke end from the hub.

5. Attaching a new spoke.

6. Screw on a new nipple and tension the spoke (see "4.3 Changing a spoke: Basics" on page 27).

7. True the wheel.

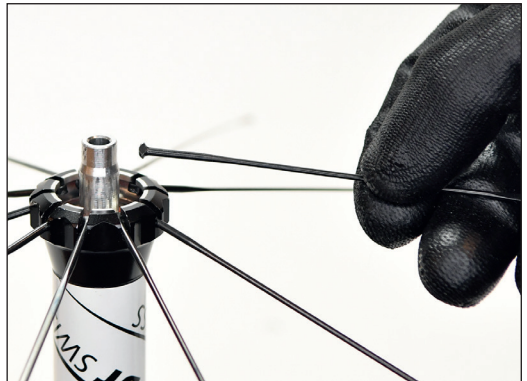

8. Check the condition of the ball bearing.
9. If heavily contaminated, clean and lightly grease the bearings.
10. Mount the end cap



5. TROUBLE SHOOTING

5.1 TROUBLE SHOOTING HUBS

Problem	Reason	Solution
Freewheel is blocked	Spacer was forgotten during assembly.	Check correct assembly: Ratchet hub: "Overview", page 14. Ratchet EXP hub: "Overview", page 20
	Spacer was compressed by overtightening the thru axle.	Measure the length of the spacer. If the spacer is shorter than 15.4 mm, it must be replaced.
Freewheel does not engage / slips	One or both ratchets are mounted upside down.	Check correct assembly: Ratchet hub: "Overview", page 14. Ratchet EXP hub: "Overview", page 20
	Too much or wrong grease on the ratchets.	Clean and grease ratchets.
	Ratchets are worn.	Replace ratchets.
	One or both springs were forgotten during assembly.	Check correct assembly: Ratchet hub: "Overview", page 14. Ratchet EXP hub: "Overview", page 20
Hub has axial play	Ball bearings were not mounted correctly.	Check correct assembly: Ratchet hub: "Overview", page 14. Ratchet EXP hub: "Overview", page 20
	Ball bearings are worn out.	Replace ball bearings.
Hub rotates stiffly	Ball bearings are worn out.	Replace ball bearings.
	Ball bearing non drive side too tight.	Check correct assembly: Ratchet hub: "Overview", page 14. Ratchet EXP hub: "Overview", page 20
	Mounting sequence of the ball bearings not observed.	
Hub makes noise	Ball bearings are worn out.	Replace ball bearings.
Notches from the cassette on the freewheel body.	The steel cassette works itself into the alloy web of the freewheel body.	Remove bad notches on the freewheel body using a file.
Freewheel body rotates with difficulty.	Ball bearings in the freewheel body are worn out.	Replace freewheel body.
Freewheel is too noisy / too quiet.	The perception of the freewheel sound is very subjective. While some riders prefer a loud freewheel sound, other riders want a quiet freewheel. In principle, the freewheeling sound can be influenced by the amount of grease between the ratchets. Less grease increases the freewheeling sound, but at the same time leads to higher wear.	

5.2 TROUBLE SHOOTING WHEELS

Problem	Reason	Solution
Wheel has lateral or radial runout	Loose spokes or external force	True the wheel and check spoke tension, adjust if necessary
Wheel feels "soft"	Check maximum permissible system weight	If exceeded, replace wheels with new ones corresponding to the system weight
	Check spoke tension	correct if necessary
	Check clamping in the bike	tighten more strongly if necessary (axle or quick release)
Nipples loosen	check maximum permissible system weight, ensure that this is not exceeded	Re-build wheel with new PL nipples or Spoke Freeze
Creaking noises from spoke crossings	Friction of the spokes at crossing points	short term: Lightly grease/oil crossing points Long-term: have new spokes fitted by Service Center
Clicking noise from nipple and / or PHR Washer	worn-in nipples/PHR washers	Have nipple and PHR washer replaced by Service Center
Wheel jams, rotates sluggishly when quick release or axle is tightened	slammed spacer in the hub	Replace spacer
Air loss with TL setup	TL tape perforated or otherwise damaged	apply new TL tape
Decreasing braking effect with rim brakes	worn or dirty brake surfaces	Clean braking surface and pads, replace rim if necessary

6. TECHNICAL DATA

Further technical data, such as spoke types, spoke lengths etc., can be found in the Product Support Tool at www.dtswiss.com.

Technical data of products from older model years can also be found in the DT Swiss Techbook.

6.1 SPOKE TENSION

		max. permissible spoke tension of the higher tensioned wheel side [N]	min. permissible spoke tension of the higher tensioned wheel side [N]	average spoke tension of the higher tensioned wheel side [N]
Disc Brake	Front wheel	1 200	950	1150 - 1000
	Rear wheel	1 300	1 050	1250 - 1100
Rim Brake	Front wheel	1 100	900	1050 - 950
	Rear wheel	1 300	1 050	1250 - 1100
Hybrid	Front wheel	1 300	1 050	1 250 - 1 100
	Rear wheel	1 400	1 150	1 350 - 1 200

6.2 TOLERANCES

Wheel type		Lateral runout [mm]	Radial runout [mm]	Dish [mm]	
ROAD	carbon rim brake	0.3	0.5	0.3	
	carbon disc brake	0.3	0.5	0.3	
	Aluminum welded	0.3	0.3	0.3	
	Aluminum sleeved	0.4	0.4	0.4	
MTB	Carbon	Inner width <30 mm	0.3	0.5	0.3
		Inner width >30 mm	0.35	0.5	0.35
	Aluminium	Inner width <30 mm	0.4	0.4	0.4
		Inner width >30 mm	0.4	0.5	0.4

DT SWISS AG

Längfeldweg 101
CH - 2504 Biel/Bienne
service.ch@dtswiss.com

DT SWISS, INC.

2493 Industrial Blvd.
USA - Grand Junction, CO 81505
techusa@dtswiss.com

DT SWISS (FRANCE) S.A.S.

Parc d'Activites de la Sarrée
Route de Gourdon
F - 06620 Le Bar sur Loup
service.fr@dtswiss.com

DT SWISS ASIA LTD.

No.5, Jingke 5th Rd., Nantun District
Taichung City 408
Taiwan (R.O.C.)
service.tw@dtswiss.com

DT SWISS DEUTSCHLAND GmbH

Albert-Einstein-Strasse 3
59302 Oelde
Germany
service.de@dtswiss.com

DT SWISS POLSKA Sp. z o.o.

ul. Towarowa 36
PL-64-600 Oborniki
Poland
service.pl@dtswiss.com

Subject to technical alterations, errors and misprints excepted.

All rights reserved.

© by DT SWISS AG

www.dtswiss.com

WXD1000000861S